

# **CLEAR-COM ENCORE**

**MS-704    FOUR-CHANNEL MAIN STATION**

**RM-704    FOUR-CHANNEL REMOTE STATION**

## **I N S T R U C T I O N   M A N U A L**

MS-704/RM-704 Four-Channel Main/Remote Stations Instruction Manual  
© 2007 Vitec Group Communications  
All Rights Reserved

Part Number 810345Z Rev. 2

Vitec Group Communications, LLC  
850 Marina Village Parkway  
Alameda, CA 94501  
U.S.A

Vitec Group Communications  
7400 Beach Drive  
Cambridge Research Park  
Cambridgeshire  
United Kingdom  
CB25 9TP

Vitec Group Communications  
Room 1806, Hua Bin Building  
No. 8 Yong An Dong Li  
Jian Guo Men Wai Ave  
Chao Yang District  
Beijing, P.R. China 100022

**Clear-Com** is a registered trademark of Vitec Group Communications.  
The Clear-Com **Logo** is a registered trademark of Vitec Group Communications.

# CONTENTS

<b>OPERATION</b> . . . . .	<b>1-1</b>
Introduction . . . . .	1-1
The Clear-Com Concept . . . . .	1-1
Understanding the MS-704/RM-704 Main and Remote Stations . . . . .	1-2
Operation . . . . .	1-4
Normal Operation . . . . .	1-4
Intercom Power Status Lights (MS-704) . . . . .	1-5
Selecting Microphones and Enabling the Speaker . . . . .	1-5
Listening to Intercom Channels . . . . .	1-5
Talking on Intercom Channels . . . . .	1-5
The All-Talk Function . . . . .	1-6
Monitoring Main Program . . . . .	1-6
Sending and Receiving Call Signals . . . . .	1-6
Linking Intercom Channels Together (MS-704) . . . . .	1-6
The Announce Function . . . . .	1-6
Remote Mic Kill Function (MS-704) . . . . .	1-6
Hidden Front Panel Options and Adjustments . . . . .	1-7
DIP Switch Options . . . . .	1-7
Hidden Adjustment Controls . . . . .	1-8
Rear Panel Options . . . . .	1-9
Intercom Line Termination (MS-704) . . . . .	1-9
Short-Circuit and and Overload Conditions . . . . .	1-9
Summary of Front-Panel Lights . . . . .	1-10
<b>INSTALLATION</b> . . . . .	<b>2-1</b>
Installation Overview . . . . .	2-1
Intercom Line Connection . . . . .	2-1
Line Termination . . . . .	2-1
Fail-Safe Power . . . . .	2-2
Connecting Intercom Channels on RM-704 . . . . .	2-4
Power Distribution and Short Circuit Protection . . . . .	2-5
Intercom Cable Considerations . . . . .	2-6
Portable Installation Cable . . . . .	2-6
Permanent Installation Cable . . . . .	2-6
Wiring Diagram . . . . .	2-6
Ground Isolation . . . . .	2-7
Physical Installation . . . . .	2-8
Description of Connectors . . . . .	2-8
Headset Connector (Front Panel) . . . . .	2-8
Panel Mic Connector (Front Panel) . . . . .	2-8
Intercom Line Connectors (Rear Panel) . . . . .	2-9
Program Input (Rear Panel) . . . . .	2-9
Announce Output (Rear Panel) . . . . .	2-10
IFB/Hot Mic (Rear panel, 1/4 inch Phone Jack) . . . . .	2-10
Accessory (Rear Panel, DB-15F) . . . . .	2-10

Internal Option Jumpers . . . . .	2-12
IFB Mode . . . . .	2-12
Run/Test Mode Jumper . . . . .	2-12
Program Audio Feed to Announce Output Jumper . . . . .	2-12
<b>MAINTENANCE . . . . .</b>	<b>3-1</b>
Introduction . . . . .	3-1
MS-704 Block Diagram . . . . .	3-1
RM-704 Block Diagram . . . . .	3-2
<b>TECHNICAL SPECIFICATIONS . . . . .</b>	<b>4-1</b>
MS-704/RM-704 Four-Channel Stations . . . . .	4-1
<b>LIMITED WARRANTY . . . . .</b>	<b>5-1</b>
Warranty Period . . . . .	5-i
Technical Support . . . . .	5-i
Warranty Repairs and Returns . . . . .	5-ii
Non-Warranty Repairs and Returns . . . . .	5-ii
Extended Warranty . . . . .	5-ii
Service Contract . . . . .	5-iii
Liability . . . . .	5-iii

# IMPORTANT SAFETY INSTRUCTIONS

*Please read and follow these instructions before operating this product.*

1. Read these instructions.
2. Keep these instructions.
3. Heed all warnings.
4. Follow all instructions.
5. Do not use this apparatus near water.
6. Clean only with dry cloth.
7. Do not block any ventilation openings. Install in accordance with the manufacturer's instructions.
8. Do not install near any heat sources such as radiators, heat registers, stoves, or other apparatus (including amplifiers) that produce heat.
9. Do not defeat the safety purpose of the polarized or grounding-type plug. A polarized plug has two blades, with one wider than the other. A grounding-type plug has two blades and a third grounding prong. The wide blade or the third prong are provided for your safety. If the provided plug does not fit into your outlet, consult an electrician for replacement of the obsolete outlet.
10. Protect the power cord from being walked on or pinched particularly at plugs, convenience receptacles, and the point where they exit from the apparatus.
11. Only use attachments/accessories specified by the manufacturer.
12. Use only with the cart, stand, tripod, bracket, or table specified by the manufacturer, or sold with the apparatus. When a cart is used, use caution when moving the cart/apparatus combination to avoid injury from tip-over.
13. Unplug this apparatus during lightning storms or when unused for long periods of time.
14. Refer all servicing to qualified service personnel. Servicing is required when the apparatus has been damaged in any way, such as power-supply cord or plug is damaged, liquid has been spilled or objects have fallen into the apparatus, the apparatus has been exposed to rain or moisture, does not operate normally, or has been dropped.
15. **WARNING:** To reduce the risk of fire or electric shock, do not expose this product to rain or moisture.

Please familiarize yourself with the safety symbols in Figure 1. When you see these symbols on this product, they warn you of the potential danger of electric shock if the main station is used improperly. They also refer you to important operating and maintenance instructions in the manual.



This symbol alerts you to the presence of uninsulated dangerous voltage within the product's enclosure that might be of sufficient magnitude to constitute a risk of electric shock. Do not open the product's case.



This symbol informs you that important operating and maintenance instructions are included in the literature accompanying this product.

*Figure 1: Safety Symbols*

## EMC AND SAFETY

The MS-704 and RM-704 stations meet all relevant CE, FCC, UL (MS-704 only), and CSA specifications set out below:

EN55103-1 Electromagnetic compatibility. Product family standard for audio, video, audio-visual, and entertainment lighting control apparatus for professional use. Part 1: Emissions.

EN55103-2 Electromagnetic compatibility. Product family standard for audio, video, audio-visual, and entertainment lighting control apparatus for professional use. Part 2: Immunity.

UL 60065-7, CAN/CSA-C22.2 No.60065-3, IEC 60065-7 Safety requirements.

And thereby compliance with the requirement of Electromagnetic Compatibility Directive 2004/108/EC and Low Voltage Directive 2006/95/EC

This device complies with Part 15 of the FCC Rules. Operation is subject to the following two conditions: (1) this device may not cause harmful interference, and (2) this device must accept any interference received, including interference that may cause undesired operation.



# OPERATION

## INTRODUCTION

Congratulations on choosing this Clear-Com product. Clear-Com was established in 1968 and remains the market leader in providing intercoms for entertainment, educational, broadcast and industrial applications. The ruggedness and high build-quality of Clear-Com products defines the industry standard. In fact, many of our original belt packs and main stations are still in daily use around the world.

*Clear-Com manufactures a wide variety of both portable and fixed installation units. All are compatible with each other.*

We recommend that you read through this manual completely to better understand the functions of the MS-704 and RM-704. If you encounter a situation or have a question that this manual does not address, contact your dealer or call Clear-Com directly. Our applications support and service people are standing by to assist you. (Refer to Chapter 5, “Warranty” for contact information.) Thank you for selecting Clear-Com for your communications needs.

## THE CLEAR-COM CONCEPT

Clear-Com is a closed-circuit intercom system that consistently provides high-clarity communication in high-noise and low-noise environments. A basic system consists of a single- or multi-channel power supply or main station connected to various single- or multi-channel remote stations, such as belt packs and loudspeaker stations.

Clear-Com manufactures a wide variety of both portable and fixed-installation units. All are compatible with each other. Clear-Com intercom systems can also interface with other communication systems and devices.

Clear-Com is a distributed amplifier system; each main and remote station houses its own mic preamplifier, headset or speaker power amplifier, and signaling circuitry. Stations bridge the intercom line at a very high impedance and place a minimum load on the line. The audio level always remains constant, and does not fluctuate as stations leave and join the network. Low-impedance mic input lines and specially-designed circuitry make Clear-Com channels virtually immune to RFI and dimmer noise.

Clear-Com stations are interconnected with two-conductor, shielded microphone cable. Portable stations are connected with two conductor cables with 3-pin XLR connectors. One wire carries the DC power from a main station or power supply to all remote stations, and the other wire carries 2-way (duplex) audio information. The shield acts as a common ground. One termination (per channel) is needed throughout the intercom network, and is usually located in the main station or power supply.

Clear-Com main stations, power supplies and certain remote stations each have an auxiliary program input with its own volume control, which allows an external audio source to be fed to the intercom system.

Visual signal circuitry (call lights), a standard feature on all main and remote stations, allows the user to attract the attention of operators who have removed their headsets.

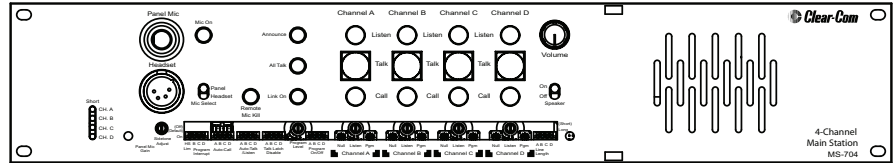

MS-704

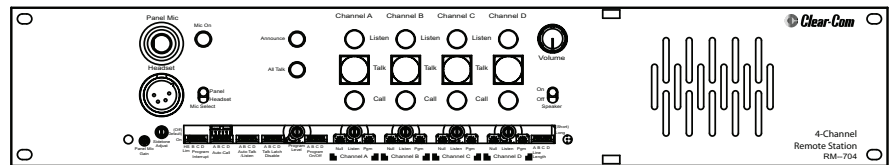

RM-704

Figure I-1: MS-704 and RM-704 Front Panels

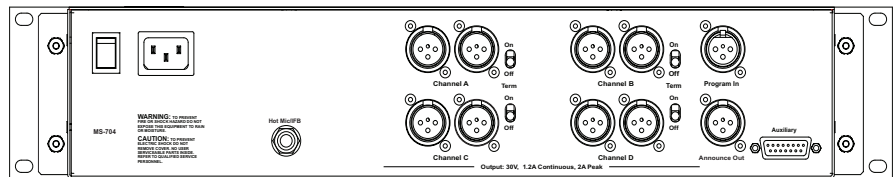

Figure I-2: MS-704 Rear Panel

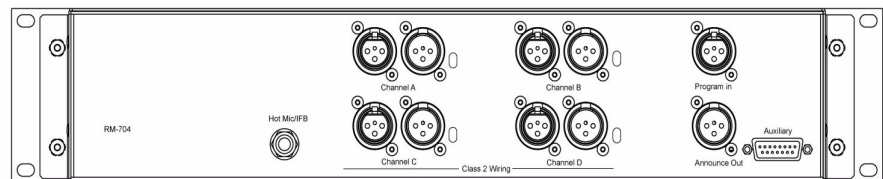

Figure I-3: RM-704 Rear Panel

## UNDERSTANDING THE MS-704/RM-704 MAIN AND REMOTE STATIONS

The MS-704 and RM-704 intercom stations are four-channel microprocessor-controlled stations intended to work with other Clear-Com party-line products. Both stations have a speaker, provisions for installing a panel microphone, and a headset connector.



The MS-704 is a four-channel main station that contains a no-fail system power supply. The RM-704 is a four-channel remote station intended to be powered from the intercom line.

The following is a list of features found in the MS-704 and RM-704 intercom stations:

- **MICROPROCESSOR CONTROL:** Most aspects of station operation are under microprocessor control.
- **REMOVABLE ACCESS PANEL:** A removable access panel allows access to most controls and option DIP switches.
- **INDIVIDUAL CHANNEL CONTROLS:** Each channel has individual *talk*, *listen*, and *call* pushbuttons for each channel.
- **MOMENTARY/LATCHING TALK BUTTONS:** The talk buttons have a momentary and latching action depending on how the button is used. The latching function can be defeated with DIP switches.
- **INDIVIDUAL CHANNEL ADJUSTMENTS:** Each channel has individual listen level controls, channel null adjustments, and program feed level controls.
- **MULTIPLE PROGRAM INPUTS:** Multiple program inputs are provided for local station monitoring and program feed to intercom lines for local talent cuing (IFB).
- **INTERNAL IFB (IFB - Interrupt Foldback of program feeds):** Program can be fed to each channel and interrupted (IFB) when a talk function is active or when a call signal is received on that channel. An internal jumper determines whether the IFB function is talk- or call-signal activated.
- **LINK FUNCTION (MS-704):** The MS-704 has a link function that places all channels into a common party-line at the push of a single button.
- **ALL-TALK:** An all-talk button allows instant access to all channels.
- **ANNOUNCE FUNCTION:** An announce button allows external paging. A set of relay contacts is provided to control an external system.
- **PROGRAM FEED OVER STAGE ANNOUNCE:** An internal jumper allows the main program feed to be fed to the stage announce output. The program is automatically interrupted when the announce button is pressed.
- **MIC ON/OFF SWITCH:** A separate mic on/off push-button allows turning the microphone off without upsetting the setting of talk switches.
- **REMOTE MIC KILL SWITCH (MS-704):** Front-panel switch allows you to turn off all latched talks on remote stations and beltacks.
- **EXTERNAL MIC ON/OFF INPUT:** An external logic input allows the mic on/off function to be switched remotely.
- **EXTERNAL IFB and HOT MIC OUTPUT:** A rear panel jack provides direct connection to Clear-Com's external IFB system such that the station's microphone can be used in the external IFB system. A buffered unswitched output of the selected microphone is also available.

- **SPEAKER ON/OFF SWITCH:** The speaker may be turned on and off with a front panel switch.
- **SPEAKER DIMMING:** Whenever a talk is active, the speaker output is dimmed approximately 6 dB to prevent feedback.
- **PANEL MIC GAIN:** The preamplifier for the panel microphone has a gain trim adjustment to allow field trimming. Adjustment of the panel microphone gain also varies the frequency response of the preamplifier to compensate for feedback when the microphone is used up close.
- **POWER SUPPLY WITH SHORT CIRCUIT PROTECTION:** The MS-704 features redundant powering to remote stations by providing separate short-circuit-protected power sources to each of the four intercom lines. A short on one intercom line will not bring the whole system down. Short circuit indicators are provided on the front panel for each channel.
- **HEADSET AUDIO LIMITER:** The headset audio limiter restricts the maximum audio level heard in the headset to protect the hearing of the user. You can turn this feature on or off with one of the front-panel dip switches.

## OPERATION

Once installed and operational, the MS-704 and RM-704 intercom stations are easy to operate. The following sections describe normal operation of the units, use of controls available under the access panel, and abnormal operation of the power distribution system.

Some of the following functions are exclusive to the MS-704 and are marked as such.

### NORMAL OPERATION

Normal operation of the MS-704 and RM-704 requires access only to the front panel controls. The following is a brief description of how to use the front panel controls in day-to-day operation.

There are option DIP switches and adjustment controls behind the access panel in the lower portion of the front panel. To gain access to the switches and controls, pull on the two latches on either end of the access panel and remove it.

This section discusses the following subjects:

- Intercom power status lights
- Selecting microphones and enabling the speaker
- Listening to intercom channels
- Monitoring main program
- Talking on intercom channels
- The all-talk function
- Sending and receiving call signals
- Linking intercom channels together (MS-704)

- The announce function

### **Intercom Power Status Lights (MS-704)**

The four red *short* lights are failure indicators for each of the four intercom lines. These lights will assist in locating a shorted or overloaded channel. Within as little as ½ second of automatically cutting off power to an overloaded intercom line, the MS-704 will attempt to turn power on again. This allows momentary short or overload conditions to clear automatically. Shorts are normally caused by miswiring or damaged cables. Overloads are generally caused by connecting too many belt packs and stations to an intercom line.

Clear-Com's advanced fail-safe design can sense the difference between a short or an overload to optimally protect itself. Power is restored in as little as ½ second, depending upon whether there was a single or multiple short or overload. The other channels continue to operate normally. The MS-704's advanced fail-safe circuit will bring the power back up even under full load conditions. Front-panel lights indicate a fault on any of the four channels.

When the station is first turned on, all four *short* lights are normally *off*.

### **Selecting Microphones and Enabling the Speaker**

To select the desired microphone, move the *microphone select* switch to the appropriate position: either “panel” or “headset.”

The *mic on* pushbutton allows turning the microphone on or off. The mic on pushbutton lights blue when the microphone is active.

The microphone will be turned on automatically whenever a *talk* function is activated as it is assumed that you wish to talk. If one or more *talks* are active, you may turn the microphone off without unlatching the active talks.

The speaker may be turned *on* and *off* with the *speaker* switch.

### **Listening to Intercom Channels**

To listen to an intercom channel, press the *listen* button for the desired channel. The listen button lights green to indicate that the listen function is on.

The *listen level* control (below the *call* button) for that channel is usually set to full on position and the listening volume is set by the *intercom volume* control to the left of the speaker.

If several channels are being listened to at the same time, it might be desirable to adjust the individual listen levels of each channel for the desired mix.

### **Talking on Intercom Channels**

To talk on an intercom channel, press the desired *talk* button. Pressing and holding the button will cause the function to be active only while the button is held (*momentary*). Pressing and releasing the button quickly will cause the function to latch on if it was off or turn off if it was on (*latching*).

The latching function can be defeated on an individual channel with an option DIP switch beneath the access panel (*latch disable* DIP switch).

The button will be illuminated blue when the talk function is off and amber when the talk function is on.

Another option allows the automatic setting of a *listen* function whenever a talk is active (*auto-listen* DIP switch) for each channel.

### **The All-Talk Function**

Pressing the button marked *all talk* sends the selected microphone to all channels while the button is pressed (*momentary* only). This button lights amber when pressed.

### **Monitoring Main Program**

The *main program* input is the one on the XLR connector on the rear panel. To listen to the main program in the speaker or headphone, adjust the *program level* control just below the *link* and *all talk* pushbuttons.

### **Sending and Receiving Call Signals**

To send a *call* signal on an intercom channel press the *call* button for that channel. This is a *momentary* function.

If the *auto-call* option is selected for that channel, activating a *talk* button will also send a *call* to that channel.

Receiving a *call* signal is indicated by a flashing red *call* button.

### **Linking Intercom Channels Together (MS-704)**

A pushbutton allows the connecting of intercom channels B, C, and D to channel A. The *link* pushbutton is latching in action. The *link* button illuminates amber when all channels are linked together. In the latched position, the entire station operates as one party line.

*Talk* and *listen* buttons are non-functional on channels B, C, and D when they are linked to channel A.

### **The Announce Function**

A single pushbutton sends the active microphone's audio to the *announce* output on the rear panel. Any active talks are disabled while the announce button is held. The announce button illuminates amber when held. *Talk* and *listen* latches are not reset, but the microphone's audio does not go to the intercom line while the announce function is active. A set of relay contacts are activated to control some external device.

There is an option which allows program audio to be fed to the *announce* output. If this option is enabled, the announce pushbutton interrupts this audio when it is pressed. Program audio feed to the announce output is selected by setting jumper *J11* on the *main* board to the *on* position.

### **Remote Mic Kill Function (MS-704)**

When you press the *remote mic kill* pushbutton, the *talk* function shuts off for every belt-pack on all four channels. If the talk functions of a large number of

beltpacks have inadvertently been left activated, incidental noise and talking can make it difficult or impossible to communicate on the party line intercom. The remote mic kill button can be pressed to quiet the line in this situation. Those needing to communicate can then set their *talk* functions to *on* as needed.

*Note: The remote mic kill button only functions if the MS-704 main station is powering all of the stations in the system. Pressing the button momentarily interrupts power to the other beltpacks and stations in the system. If there are other power supplies or main stations in the system, then the remote mic kill switch cannot interrupt power and therefore cannot work.*

## HIDDEN FRONT PANEL OPTIONS AND ADJUSTMENTS

This section describes the option DIP switches and various adjustment controls behind the access panel on the front panel. These option switches and controls are usually set and not used in daily operation of the unit.

To gain access to these controls, pull on the two latches on either end of the access panel and remove it.

### DIP Switch Options

The unit is shipped with all DIP switches, except the Headset Audio Limiter, in their default positions (up). The Headset Audio Limiter dip switch is shipped in the down (on) position.

The following functions are enabled with DIP switches:

- **HEADSET AUDIO LIMITER:** The HS dip switch turns the headset audio limiter on or off. Unless an especially high volume is needed, this switch should be left in the *on* position to protect the hearing of the user.
- **INTERRUPT ENABLE:** Three DIP switches (B, C, and D) enable the *program interrupt* function on channels B, C, and D. Program interrupt is not available on channel A.
- **AUTO-CALL:** Four DIP switches (one for each channel) enable automatically sending a *call* signal whenever a *talk* is active on the enabled channel.
- **AUTO-TALK/LISTEN:** Four DIP switches (one for each channel) enable automatically setting the *listen* function whenever a *talk* is active on the enabled channel.
- **TALK LATCH DISABLE:** Four DIP switches (one for each channel) disable the latching action of the selected channel.
- **PROGRAM ON/OFF:** Four DIP switches (one for each channel) enable feeding the main program input to the selected intercom channel. The main program input is the one on the XLR-3F on the rear panel.

The other four program inputs in the auxiliary connector feed their respective intercom channels all of the time. The only way to turn off the Auxiliary feed to a channel is to turn its individual control off.

- **LINE LENGTH:** Four DIP switches (one for each channel) allow the optimization of the nulling circuitry for each channel. The default (up position) is for lines less than 400 ft. (122 m). The down position is for lines longer than 400 ft. (122 m).

### Hidden Adjustment Controls

Various adjustments are available beneath the front access panel.

- **PANEL MIC GAIN:** This control trims the panel microphone preamplifier gain to compensate for different uses of the station.

The unit is shipped from the factory in the minimum gain position (fully counter-clockwise). This level matches the headset microphone level when the panel microphone is worked up close. Raising the gain from the factory setting should be done carefully, as too much gain will increase the background noise in the intercom making it unusable.

- **CHANNEL NULL ADJUST:** The screwdriver-adjustable control beneath each *talk* pushbutton marked *null* allows nulling of the hybrid circuitry associated with each listen channel.

The amount of null in the listen circuitry varies with the length of the intercom line. Adding or removing stations and intercom cable will change the null. For optimum performance, the *null* control will need to be adjusted each time there is some change in the intercom line wiring.

If a panel microphone and speaker is being used, the setting of the *null* control is critical to prevent feedback.

To adjust the *null* control on a given channel:

1. Turn the *sidetone adjust* control just below the headset connector to minimum.
  2. Set a *talk* to the channel to be adjusted or send some program to the channel and adjust the *null* control for the channel for minimum level in the headphone. If the headset microphone is being used, hum or gently scratch it for a continuous signal source to null on. If a good null is not attainable, switch the *long/short* DIP switch for the channel (to the far right of the hidden adjustments) to its opposite setting. Use the setting that produces the best results.
  3. Repeat the adjustment for all four channels on the station.
  4. Adjust the *sidetone adjust* control for the desired amount of sidetone in the headset.
- **CHANNEL PROGRAM FEED LEVEL:** Beside the *null* control for each channel there is a control marked PGM, which adjusts the amount of *program* being sent to that channel.

Each channel has two program sources:

1. The main program that is input from the rear panel XLR connector may be enabled for a given channel with the *program on/off* DIP switches for the channel.

2. The *auxiliary input* connector has four individual program inputs for each channel. These inputs cannot be disabled with front-panel DIP switches.

## REAR PANEL OPTIONS

This section describes the switches on the rear panel. These switches and controls are usually set and not used in daily operation of the unit.

### INTERCOM LINE TERMINATION (MS-704)

The MS-704 has switch-selectable intercom line termination networks. The RM-704 is a remote station and therefore does not have terminating networks available. If more than one MS-704 (or any other master station) is installed on the same intercom line, then all of the terminations in all of the stations except one must be disabled.

*CAUTION: If the link function is to be used on an MS-704 and there is more than one MS-704 in the system, it can only be used on the unit that provides termination.*

The terminations are enabled or disabled with switches on the rear panel. Each channel is marked clearly on the panel. Set the switches to the *off* position to disable the terminations in the station. **The MS-704 is shipped from the factory with all four lines terminated.**

## SHORT-CIRCUIT AND AND OVERLOAD CONDITIONS

If a short circuit condition appears on any of the four intercom lines, the sense circuitry for that line will disconnect the DC power to that line only and the red “short” light for that channel will be on. After as little as 1/2 second, the MS-704 will attempt to turn power on again. This allows momentary short or overload conditions to clear automatically.

If the red “short” light remains after repeated automatic or manual attempts to restore power, then there is either a short on that intercom line or too many intercom stations have been connected to that intercom line. In this case, unplug the intercom line connected to the affected channel and its red “short” light should go out. This indicates that there is a short in that line. Follow that intercom line and break it apart in several places while it is plugged into the station to isolate the section of line that is shorted.

## SUMMARY OF FRONT-PANEL LIGHTS

Table 1 summarizes the meaning of various front-panel key colors.

Key	“On” State	“Off” State	Momentary or Latching
Microphone	Blue	Off	Latching only (activates automatically in conjunction with some other features, like “talk”)
Listen	Green	Off	Latching only (can be set to activate automatically with “talk”)
Talk/Power On	Amber	Blue (indicates that the station is receiving power, but the “talk” feature is off)	Both
Call	Red (flashing)	Off	Momentary only
Announce	Amber	Off	Momentary only
All-Talk	Amber	Off	Latching only
Link-On	Amber	Off	Latching only
Remote Microphone Kill	Amber	Off	Momentary only
Short/Overload	Red	Off	N/A

*Note: Note: To “latch” (or “lock”) a button to “on,” quickly press it once. The button is “locked” to “on” for hands-free use. Pressing the button again releases the latch. Otherwise when you press and hold a button the feature switches on, and when you release the button the feature switches off. This is called “momentary” use.*



# 2 INSTALLATION

This chapter discusses how to install the MS-704 and RM-704 intercom stations in an intercom system.

## INSTALLATION OVERVIEW

This section describes the Clear-Com concept of intercom line interconnection. The following subjects are discussed:

- Intercom line connection
- Line termination
- Station powering
- Cable considerations

### Intercom Line Connection

The MS-704 provides two male XLR-3 connectors for each intercom line.

The RM-704 provides a male and female XLR-3 connector for each intercom line, which are looped through.

### Line Termination

The fundamental concept of the Clear-Com party-line intercom is that all stations provide high impedance into a single 200-ohm system termination.

*CAUTION: An intercom line must be terminated. Care must be taken not to “double”-terminate a line. All unused intercom inputs must be terminated to keep the line drive circuits stable.*

The MS-704 provides switchable terminations of the intercom lines. Clear-Com main stations and power supplies provide switch-selectable termination networks on all intercom output lines. It is up to the user to determine where the termination will be provided. An unterminated line will cause excessive levels, possible oscillation of line drivers, and severe imbalance of hybrid null networks. A double- or multiple-terminated line will cause low levels and severe unbalance of hybrid null circuits.

Switching of the termination *on* and *off* on the MS-704 is with back panel switches. The MS-704 is shipped from the factory with all four lines terminated.

**USING THE LINK FUNCTION:** The *link* function in the MS-704 connects the four party lines together. In doing so, it also removes the terminations from channels B, C, and D such that the new party line on channel A has only one termination when *link* is activated. If there is more than one MS-704 in a system, the *link* function can only be used at the station where the terminations are set on.

## FAIL-SAFE POWER

An intercom power supply has special needs that are not met by traditionally designed power supplies. An intercom power supply must work in adverse conditions such as low AC line voltage, momentary shorts on the DC power lines to the stations, and excessive peak loads during “power-on” conditions. The following features are incorporated into the MS-704’s power supply:

- **AUTOMATIC SHORT CIRCUIT PROTECTION:** The MS-704’s internal power supply checks each channel for a short or current overload. If it detects a short the power supply will shut down that channel. A short duration short circuit will not cause the power supply to interrupt power.
- **AUTOMATIC OVERLOAD PROTECTION:** The MS-704’s internal power supply senses the difference between shorts and overloads. If an overload is detected the power supply will shut down that channel. An overload lasting a short period will not cause the power supply to interrupt power.
- **AUTOMATIC POWER RESTORE:** The MS-704’s internal power supply senses the difference between short-term and long-term shorts and overload conditions. After the first few times a short or overload occurs, the power supply will try to restore power after only 0.5 seconds. If the short or overload persists or occurs repeatedly, the power supply will take progressively longer (to a maximum of 20 seconds) to try to restore power. This protects the power supply from damage due to overheating. Once the short is removed, the channel will recover, even under a full load condition. The automatic power restore times are shown in the following chart:

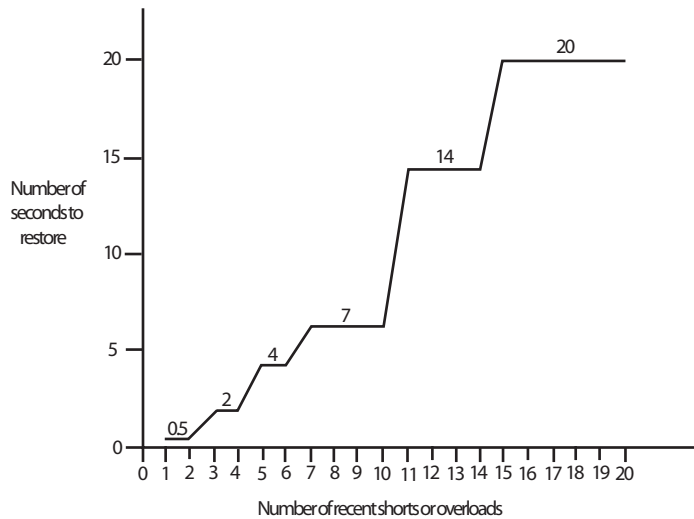

Figure 2-4: Automatic Power Restore Times

- **INDIVIDUAL CHANNEL SHORT CIRCUIT PROTECTION:** Each individual channel is separately overload and short circuit protected and may draw as much as 1.2 amperes, though the total to both channels is limited to

2 amperes. A short on any one intercom line will not bring the whole system down.

*Note: Power supply lines connected together at remote stations will disable the individual channel short circuit protection feature.*

- **FRONT PANEL “SHORT” LIGHTS:** There are four *short* lights on the front panel (one for each channel). The *short* lights illuminate steadily when an overload or short condition is detected. They blink if power to a channel has been shut off as a result of an overload or short.
- **PARALLELING MULTIPLE POWER SUPPLIES:** Multiple power supplies can be paralleled to increase system capacity. The MS-704's internal power supply will automatically detect the actions of other power supplies during overloads and short circuits to restore power as quickly as possible.
- **MULTI-CHANNEL REMOTE STATIONS MAINTAIN THE POWER LINE ISOLATION.** Internal jumpers in the RM-704 allow you to select non-isolation if needed. See the Operation chapter of this manual for more information.
- **LOW NOISE CIRCUITRY:** The direct current outputs of the MS-704's internal power supply contain very little hum and noise. The power supply does not contribute to audible noise in the remote stations and belt packs.
- **CONNECTION TO AC MAINS:** The AC power line supplies power to the MS-704's internal power supply. The power supply will accept any line voltage between 100 and 240 VAC at 50-60 Hz. It will automatically adjust to the line voltage. There is no need for a voltage selector switch or an external fuse. The unit draws a maximum of 60 VA of power from the AC line. Clear-Com power supplies can be paralleled to increase the number of remote stations that can be operated in a system.

FAIL SAFE POWER DISTRIBUTION SCHEME  
WITH SINGLE-CHANNEL REMOTE STATIONS

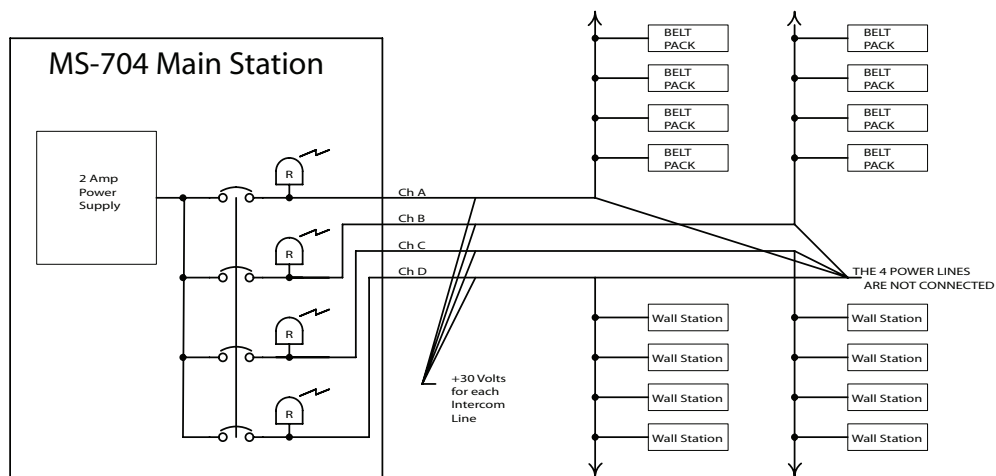

Figure 2-5: Stations Powered by Individual Channels

The illustration above shows the proper power wiring of a system powered by a single MS-704. The remote stations connected to each channel are powered from the intercom cable for that channel. In the case above, a short on any one line will only take that channel down.

It is assumed that none of the power channels are connected together in the external system wiring. However, if the power channels in a multiple-channel remote station have been bridged by connecting the internal jumpers, those channels would now have their power connected together. The system would still work except that a short circuit on any of the connected channels would cause them all to short circuit, thus taking more of the system down with a single short circuit.

### Connecting Intercom Channels on RM-704

Internal jumpers in the RM-704 allow you to defeat the power-channel isolation of the unit, as described in the following procedure.

**To connect two or more RM-704 channels together:**

1. Please observe anti-static procedures. The circuit cards can be damaged by static electricity. Please ground yourself and tools before touching any circuit cards.
2. Remove the cover of the RM-704.
3. On the main circuit board, locate the J16 six-pin jumper.

*The jumper is located on the center leftmost portion of the circuit card when viewed from the front of the station. The label "J16" appears next to it. Three jumper plugs are stored, unconnected, on the pins.*

4. To connect two channels, lift one of the jumper plugs off of the pins, and place it in the proper position, as shown in Figure 2-6.

- J16 1 ● □ Placing jumper plug over pins 1 and 2 connects channels A and B
- 2 ● □
- 3 ● □ Placing jumper plug over pins 3 and 4 connects channels B and C
- 4 ● □
- 5 ● □ Placing jumper plug over pins 5 and 6 connects channels C and D
- 6 ● □

Figure 2-6: J16 Six-Pin Jumper

5. Continue placing pins until all desired channels are connected.
6. Replace the cover of the RM-704.

**FAIL SAFE POWER DISTRIBUTION SCHEME  
WITH MULTI-CHANNEL REMOTE STATIONS**

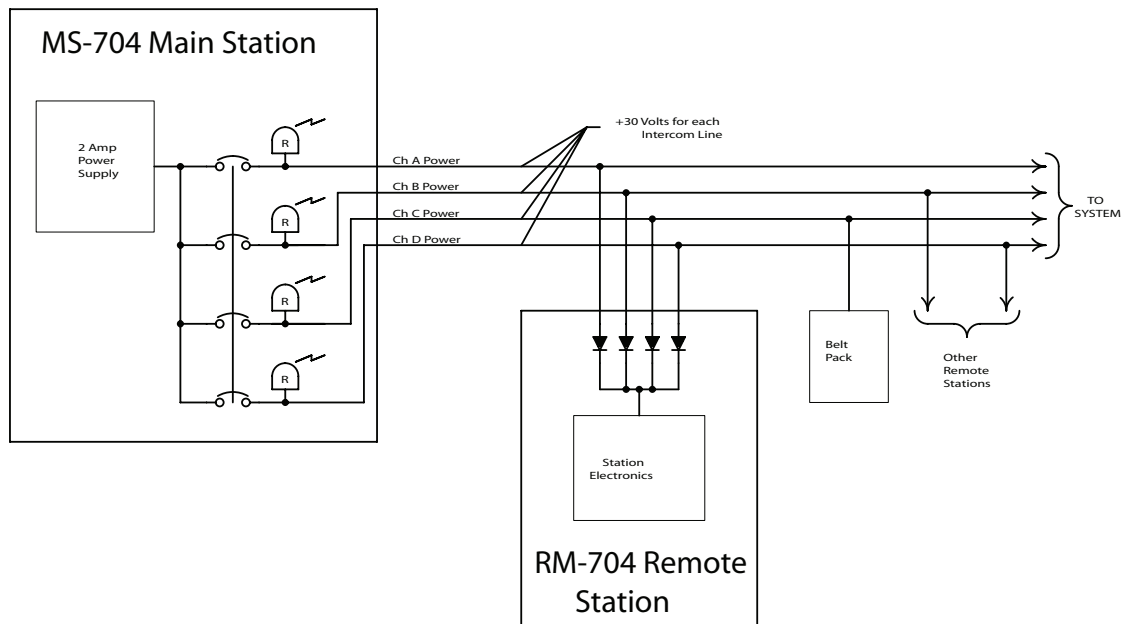

Figure 2-7: Stations Powered by Multiple Channels

The illustration above shows the power wiring of a system powered by a single MS-704. An RM-704 is connected to all four power lines through the intercom line connections. However, the blocking diodes in the RM-704 prevent a short circuit on one line affecting the others. Other single channel remote stations are also connected to individual channels.

**POWER DISTRIBUTION AND SHORT CIRCUIT PROTECTION**

Depending upon how many shorts or overloads a channel has experienced recently, the MS-704 will attempt to turn power on again within 0.5 to 20 seconds of automatically cutting off power to an overloaded channel. This allows momentary short or overload conditions to clear automatically. If the MS-704 cuts power off to one or both channels, it will indicate which channel is affected by blinking the red *short* light(s) corresponding to these channel(s). This light

will assist in locating the shorted or overloaded channel. Shorts are generally caused by miswiring or damaged cables. Overloads are generally caused by connecting too many beltacks and stations to a channel.

The current requirements of Clear-Com remote stations and beltacks vary with model and use. A station that is simply *on* and idling in the circuit may draw only a small amount of current.

The MS-704 provides DC power to operate Clear-Com beltacks and remote stations. The power is distributed between the four channels and will support up to 40 RS-601 beltacks or 10 speaker stations or 12 headset stations.

## INTERCOM CABLE CONSIDERATIONS

The Clear-Com intercom line is intended to run on a shielded pair cable. One conductor carries audio, the other conductor carries the DC power for remote stations. The shield is used for ground return for audio and power. When choosing interconnect cable, keep the following considerations in mind:

1. DC resistance of the ground or common conductor affects crosstalk. For runs longer than 500 ft. (152.5 m) do not use wire smaller than 20 gauge.
2. The capacitance of the interconnect cable affects system frequency response and sidetone stability. Total capacitance should not be greater than 0.25 uF.

## PORTABLE INSTALLATION CABLE

Practical cable for portable system interconnections is flexible, two-conductor, shielded microphone cable. We suggest you use BELDEN #1800F (24 gauge). For runs longer than 500 ft. (152.5 m) use a 20 gauge cable or larger (BELDEN #8412).

## PERMANENT INSTALLATION CABLE

Vinyl-jacketed shielded pair is the cable of choice for permanent installations. Use a low-capacitance 20 gauge wire for runs under 500 ft. (152.5 m). We suggest you use BELDEN #8762. For runs longer than 500 ft. (152.5 m), use an 18 gauge cable (BELDEN #8760). Placing the cable in conduit is recommended but not necessary.

Multi-pair cable that is individually shielded is acceptable for use in multi-channel systems. For cross-talk considerations, the shields must be tied together on both ends of the cable to produce the lowest possible DC path for ground return.

## WIRING DIAGRAM

The diagram shows using a multi-pair cable to connect two stations. Note that the power and shield wires of each channel are not connected together.

## GROUND ISOLATION

The pin #1 ground connection of each XLR connector must also be isolated from the chassis. Pin #1 should not be connected to the shell of the XLR connector.

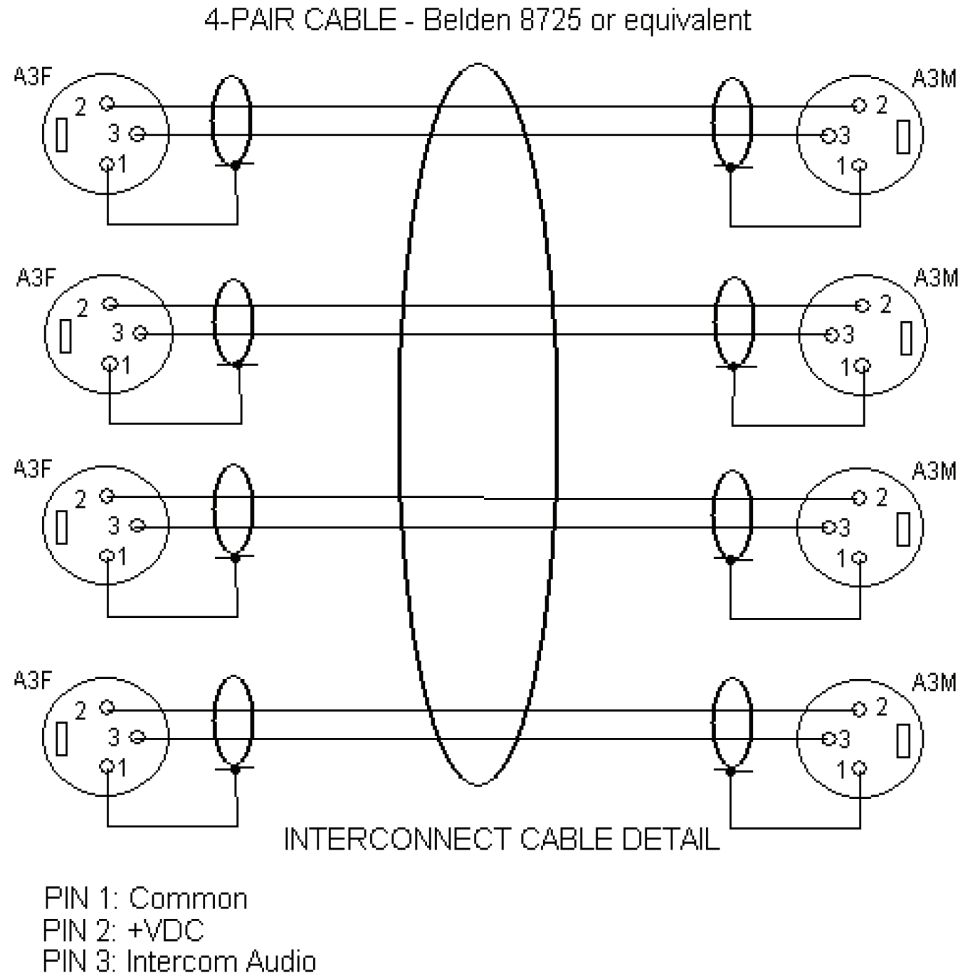

Figure 2-8: Interconnect Cable Detail

*Note: The remote stations connected to each channel are powered from the intercom cable for that channel. In the case above, a short on any one line will only take that channel down.*

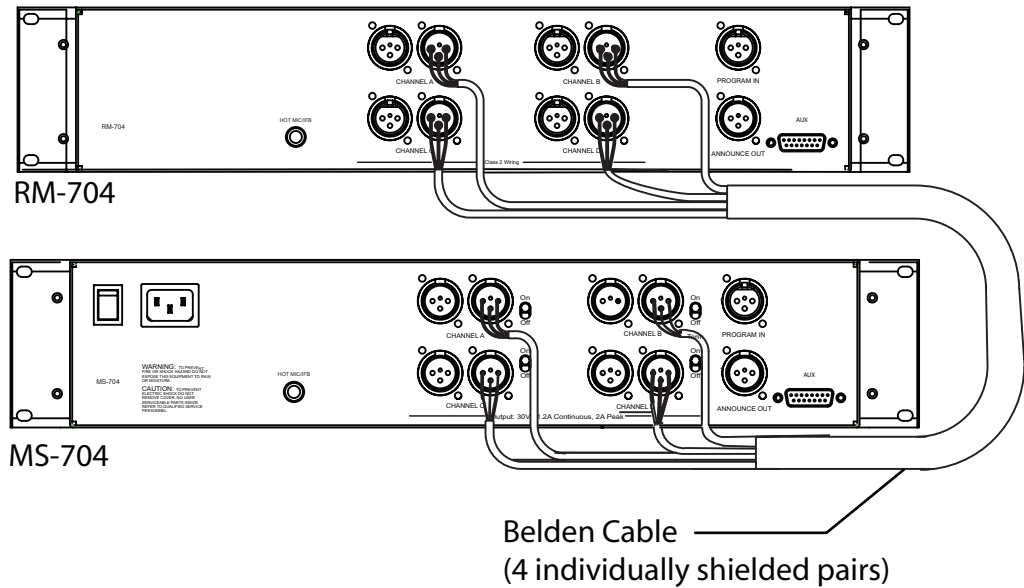

Figure 2-9: Proper power wiring of a system powered by a single MS-704

## PHYSICAL INSTALLATION

You can install the MS-704 and RM-704 units in a standard equipment rack, or you can use them as stand-alone units sitting on a table or desk. For installing in an equipment rack, the units require 3.5 in. (8.89 cm or 2RU) of rack space. The stations are 10.5 in. (26.67 cm) in depth and require at least 2.5 in. (6.35 cm) clearance in the rear to clear connectors and cables.

## DESCRIPTION OF CONNECTORS

### HEADSET CONNECTOR (FRONT PANEL)

*Note:* The following is a description of a recommended headset.

Mic Type --- Dynamic, see technical specifications for details

Wiring:

- Pin 1 --- Mic common
- Pin 2 --- Mic hot
- Pin 3 --- Headphone common
- Pin 4 --- Headphone hot

**CAUTION:** Do not tie pin #1 and pin #3 together.

### PANEL MIC CONNECTOR (FRONT PANEL)

Two plug-in panel microphones are available for use on the MS-704 and RM-704. The GM-9 is 9 in. (22.86 cm) long and GM-18 is 18 in. (45.72 cm)



long. The microphone is of the electret type. The microphone has a built-in ¼ in. (0.64 cm) phone jack for a connector. A proprietary mating receptacle is mounted on the station.

To install a GM-9 or GM-18 panel mount microphone, use the following steps:

1. Check the set screw in the mic mounting flange to make sure it is clear of the threads in the bushing.
2. Screw the microphone into the bushing hand tight.
3. If desired, set the set screw on top of the bushing to lock the mic in place.

## INTERCOM LINE CONNECTORS (REAR PANEL)

The MS-704 has a pair of male XLR-3 connectors for each intercom line. The male-male pair of connectors are wired in parallel to allow connecting multiple remote stations.

The RM-704 has a male and female pair of XLR-3 connectors for each intercom line. The male-female connectors are wired in parallel and intended for loop-through connection.

The pinout of the intercom connectors is as follows:

- Pin 1 --- Ground (shield)
- Pin 2 --- Power
- Pin 3 --- Audio

## PROGRAM INPUT (REAR PANEL)

A XLR-3F connector provides the main program input to the station. This input is fed to the front panel *program level* control for listening in the headphones or speaker. Optionally, it can be fed to each of the intercom lines with the option DIP switches marked *program select A-D*. Another option is to feed program audio to the *announce* output. This is selected by setting jumper *J11* on the main board to the *on* position.

Separate program inputs are also available for each channel via the *accessory* DB-15 connector. Refer to the section on that connector for details.

The pinout of the *program input* connector is as follows:

- Pin 1 --- Ground (shield)
- Pin 2 --- - Signal
- Pin 3 --- + Signal

## ANNOUNCE OUTPUT (REAR PANEL)

An XLR-3M connector provides the *announce* output from the station. Whenever the announce button on the front panel is pressed, the selected microphone is sent to the announce output and the announce relay is activated. Simultaneously, if the program audio feed to the announce output is enabled, it is interrupted by the announcement. Program audio feed to the announce output is selected by setting jumper *J11* on the main board to the *on* position. Refer to the section on the accessory connector for instructions on connecting to the relay contacts.

The pinout of the *announce* output connector is as follows:

Pin 1 --- Ground (shield)

Pin 2 --- - Signal

Pin 3 --- + Signal

## IFB/HOT MIC (REAR PANEL, 1/4 INCH PHONE JACK)

A 1/4 in. (0.64 cm) phone jack marked *IFB/Hot mic* provides an output signal from the selected microphone. This output is also intended to work with Clear-Com's IFB system. Consult the factory for installation instructions.

The jack connections are as follows:

Tip --- Hot mic output

Ring --- Control signal in

Sleeve --- Ground

## ACCESSORY (REAR PANEL, DB-15F)

The *accessory DB-15F* connector on the rear panel provides auxiliary program inputs for each channel, *remote mic on/off* input, *line level* output, and *announce relay* contacts. The pin assignments of the connector are as follows:

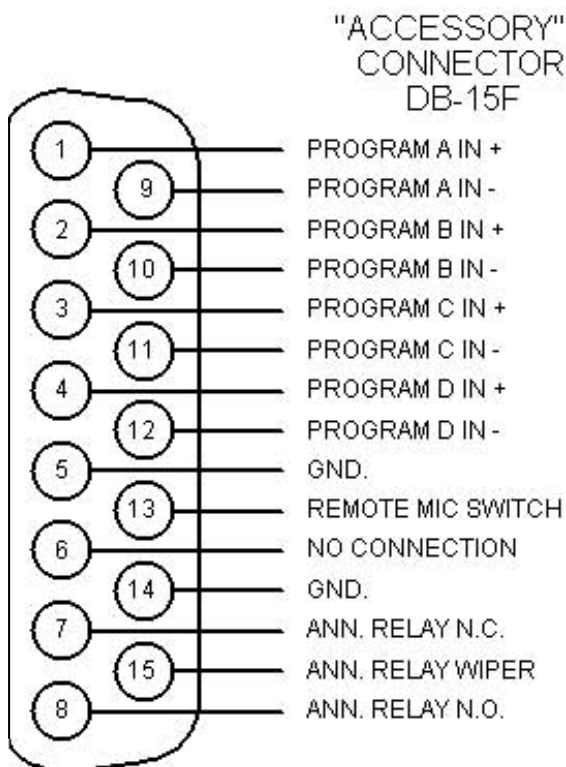

**Viewed from the rear of the connector**

*Figure 2-10: Accessory Connector*

- **AUXILIARY PROGRAM INPUTS:** Four different program inputs, one for each channel, are provided. These auxiliary program inputs can only be fed directly to their associated intercom line. The only controls that affect these inputs are the PGM-level controls associated with each channel and the internal *program interrupt* switch that is active if the function has been activated with an option DIP switch and a *talk* is active on that channel.

*These inputs are electronically balanced with a high input impedance. Refer to the illustration above for connection of the program inputs. Pins #5 or #14 can be used for connecting shields.*

- **REMOTE MIC ON/OFF SWITCH:** An external momentary pushbutton switch connected to pins #5 and #13 will duplicate the action of the front panel *mic on/off* switch.
- **ANNOUNCE RELAY CONTACTS:** A relay is provided that activates when the *announce* button is pressed and its contacts are available on the *accessory* connector. The relay contacts are rated for 2.0 amperes of DC current at 24 VDC and are electrically isolated from the rest of the station.

## INTERNAL OPTION JUMPERS

There are several jumper options inside the chassis of the MS-704 and RM-704.

*CAUTION: Remove AC power from the unit before removing the top cover.*

The following options are available:

- IFB operation mode select
- Run/test mode jumper
- Program audio feed to announce output

### IFB Mode

The MS-704 and RM-704 support two different modes of operation for the internally generated IFB function. *J10* on the main PC board (in the lower left hand corner of the board just behind the DIP switches) selects this mode. If an *interrupt enable* DIP switch is enabled for a channel, the operation will be as follows:

- **LOCAL (Talk Function Activated):** Jumper between Pins #1 and #2, factory default. When a talk is active on the channel on which the interrupt has been enabled, the program will be interrupted for the duration of the *talk*.
- **REMOTE (Call Signal Activated):** Jumper between pins #2 and #3. When a *call* is received on the channel on which the interrupt has been enabled, the program will be interrupted for the duration of the call signal on that channel. To cause an interrupt of the program from this station a call signal must be sent by pressing the call button or enabling the *auto-call* DIP switch option for that channel and activating a *talk* on that channel.

### Run/Test Mode Jumper

The J2, J12, P3, and P4 jumpers on the main printed circuit board allow a factory test mode to be invoked and should never be used for normal intercom operation.

*CAUTION: Do not move these jumpers. Moving these test jumpers may cause the MS-704 and RM-704 not to operate. Possible damage to the product may result.*

### Program Audio Feed to Announce Output Jumper

*J11* on the main board allows program audio to be fed to the *announce* output. This is selected by setting jumper *J11* to the *on* position. In this mode, pressing the announce pushbutton turns off the program audio feed to the announce output and replaces it with audio from the selected panel or headset microphone.

The factory default position for *J11* is in the *off* position, blocking program audio feed from the *announce* output.

# 3 MAINTENANCE

## INTRODUCTION

This chapter provides maintenance information, including a block diagram and troubleshooting tips.

*Caution: These servicing instructions are for use by qualified personnel only. To reduce the risk of electrical shock, do not perform any servicing other than that contained in the operating instructions unless you are qualified to do so.*

## MS-704 BLOCK DIAGRAM

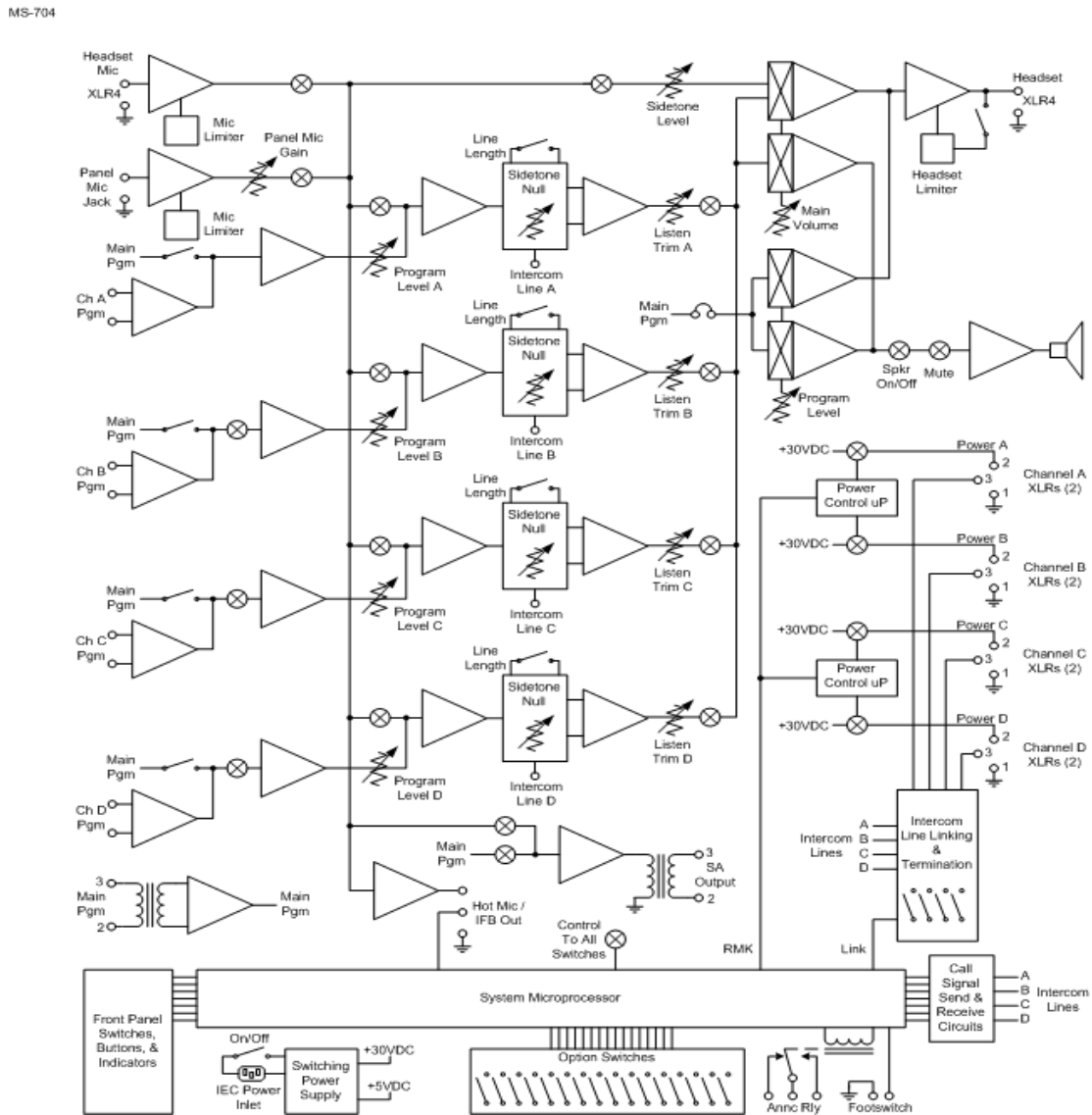

Figure 3-1 I: MS-704 Block Diagram

# RM-704 BLOCK DIAGRAM

RM-704

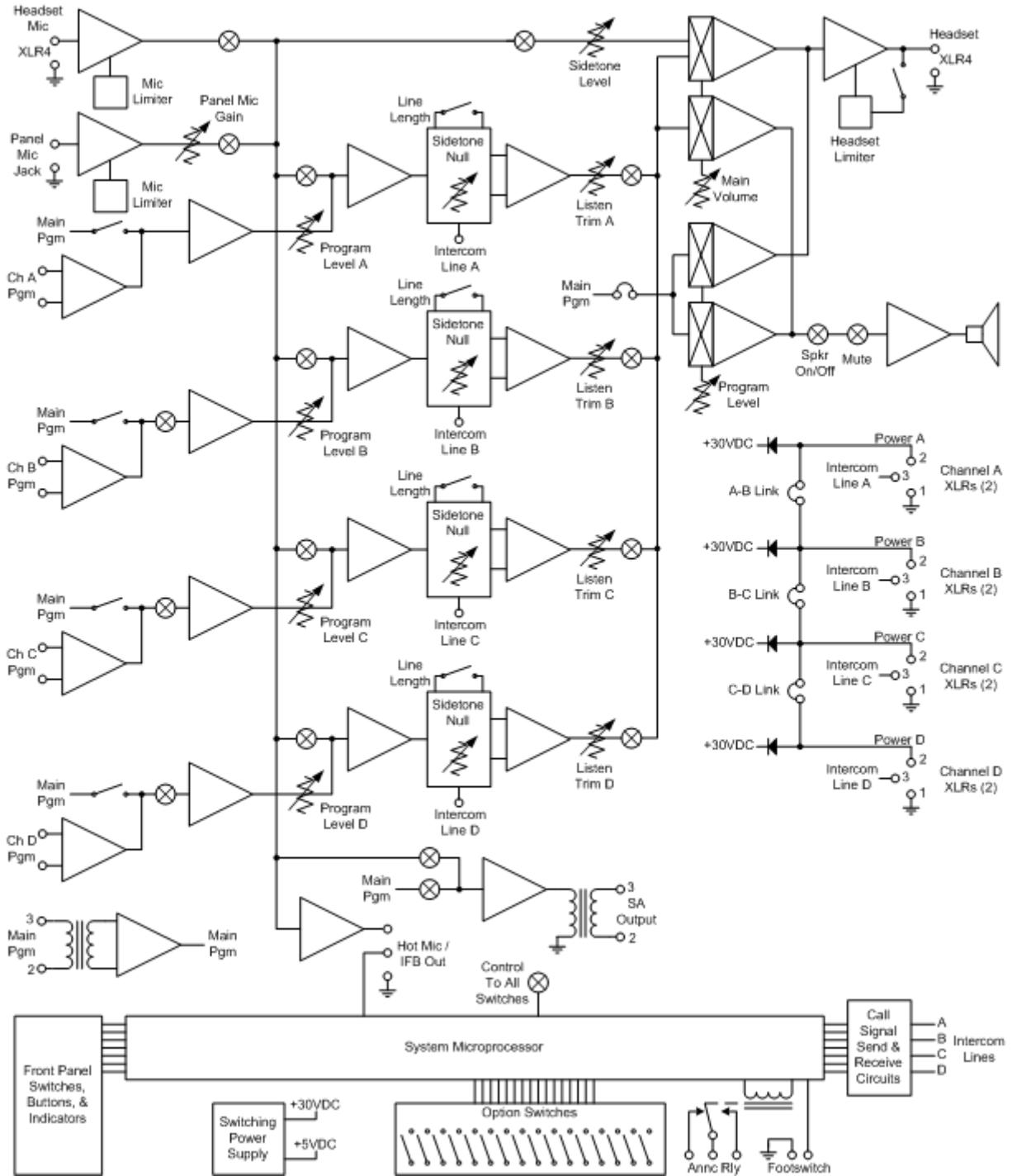

Figure 3-12: RM-704 Block Diagram

# 4

## TECHNICAL SPECIFICATIONS

### MS-704/RM-704 FOUR-CHANNEL STATIONS

dBu is an absolute measurement. 0 dBu is referenced to 0.775 volts RMS

#### Panel Microphone Input

Input Type	Electret
Input Impedance	$\geq 2K\Omega$
Mic Limiter Threshold	0dBu $\pm$ 3dB
Mic Limiter Range	$\geq 20$ dB

#### Headset Microphone Input

Input Type	Dynamic
Input Impedance	$\geq 1K\Omega$
Mic Limiter Threshold	0dBu $\pm$ 3dB
Mic Limiter Range	$\geq 17$ dB

#### Program Line Input

Maximum Level before Clipping	$\geq 20$ dBu
Input Impedance	$\geq 5K\Omega$

#### Headset Output

Load Impedance	$\geq 8\Omega$
Output Impedance	$\leq 25\Omega$
Output Limiter Threshold	+5dBu $\pm$ 3dB
Maximum Output Level before Distortion	$\geq 17$ dBu

#### Speaker Output

Load Impedance	$\geq 4\Omega$
Max Output Level before 1% Distortion	20dBu $\pm$ 2dBu

#### Party Line Output

Off Noise	$< -74$ dBu
Output Impedance	$> 10K\Omega$

#### Party Line Input

Crosstalk	$< -60$ dB
Max level before Clipping	$\geq 12$ dBu
Sidetone Null Capability	$> 25$ dB

#### Stage Announce/Balanced Line Out

Type	Balanced
Output Impedance	$\geq 200\Omega$
Load Impedance	$\geq 600\Omega$

### IFB/Hot Mic

Type	Unbalanced
Output Impedance	150Ω
Load Impedance	>= 600Ω

### Frequency Response

Panel Mic - Party Line	600 - 10KHz ± 3dB
Headset Mic - Party Line	200 - 12KHz ± 3dB
Headset Mic - Line Out	200 - 12KHz ± 3dB
Program Input - Party Line	100 - 17KHz ± 3dB
Program Input - Headset Out	200 - 10KHz ± 3dB
Program Input - Speaker Out	300 - 10KHz ± 3dB
Party Line - Headset Out	200 - 10KHz ± 3dB
Party Line - Speaker Out	300 - 10KHz ± 3dB

### Max Distortion

Panel Mic - Party Line	<= 0.5%
Headset Mic - Party Line	<= 0.5%
Headset Mic - Line Out	<= 0.5%
Program Input - Party Line	<= 0.2%
Program Input - Headset Out	<= 0.2%
Program Input - Speaker Out	<= 0.5%
Party Line - Headset Out	<= 0.2%
Party Line - Speaker Out	<= 0.5%

### Noise

Panel Mic - Party Line	< -65dBu
Headset Mic - Party Line	< -70dBu
Headset Mic - Line Out	< -55dBu
Program Input - Party Line	< -85dBu
Program Input - Headset Out	< -60dBu
Program Input - Speaker Out	< -60dBu
Party Line - Headset Out	< -50dBu
Party Line - Speaker Out	< -50dBu

### Max Gain

Panel Mic - Party Line	>= 37dB
Headset Mic - Party Line	41dB ± 2dB
Headset Mic - Hot Mic Out	55dB ± 3dB
Headset Mic - Announce Out	55dB ± 3dB
Program Input - Party Line	>= -16dB
Program Input - Headset Out	>= 18dB
Program Input - Speaker Out	>= 24dB
Party Line - Headset Out	>= 34dB
Party Line - Speaker Out	>= 40dB

### Min Gain

Panel Mic - Party Line	<= 25dB
------------------------	---------



### **Mains Power (MS-704)**

Input Voltage Range	100 - 240 VAC
Input Frequency Range	50 - 60 Hz
Input Power	<= 60 VAC
Output Voltage	30 VDC $\pm$ 0.5V
Output Current per Channel (Continuous)	1.2 A
Output Current per Channel (Peak)	2 A (Do not exceed the 1.2A rating for more than 2 seconds per 1 minute period)
Short Circuit Recovery Time (1st short)	<= 0.5 sec
Short Circuit Recovery Time >= 20 shorts in 20sec)	<= 20 sec

### **Station Capacity (MS-704)**

Up to 40 RS-601 beltpacks or 10 speaker stations or 12 headset stations distributed over all channels

### **DC Power (RM-704)**

Input Voltage Range	20-30 VDC
Input Current (Idle)	<=165 mA
Input Current (Max)	<=195 mA

### **Rear Panel Connectors (MS-704)**

Intercom:	(8) XLR-3M (2 per channel)
Announce Out:	(1) XLR-3M (audio)
Program:	(1) XLR-3F
Hot Mic / IFB Interface:	(1) 1/4 in. (0.64 cm) phone jack
Accessory	(1) DB-15F
AC Power:	IEC 320 connector

### **Rear Panel Connectors (RM-704)**

Intercom:	(4) XLR-3M (1 per channel) (4) XLR-3F (1 per channel)
Announce Out:	(1) XLR-3M (audio)
Program:	(1) XLR-3F
Hot Mic / IFB Interface:	(1) 1/4 in. (0.64 cm) phone jack
Accessory	(1) DB-15F

### **Rear Panel Controls**

(1) Power switch (MS-704)

### **Front Panel Connectors**

Panel Mic:	(1) 1/4 in. (0.64 cm) panel mounting jack
Headset:	(1) XLR-4M

### **Front Panel Controls & Indicators (MS-704)**

(1) Panel / headset mic switch  
(1) Mic on button

- (1) All talk button
- (1) Announce button
- (1) Party line link button
- (4) Program
- ON-OFF-INTERRUPT
- DIP switches
- (1) Program level control
- (4) Listen adjust controls
- (4) Channel null adjust controls
- (4) Channel program feed adjust controls
- (4) Talk buttons
- (4) Call buttons
- (4) Listen buttons
- (1) RMK button
- (1) Speaker ON-OFF switch
- (1) Speaker volume control
- (4) Short LEDs
- (1) Panel mic gain control
- (1) Sidetone adjust control
- (1) Headset audio limiter DIP switch
- (3) Interrupt enable DIP switches
- (4) Auto-call DIP switches
- (4) Auto-talk/listen DIP switches
- (4) Talk latch disable DIP switches
- (4) Line length DIP switches

### Front Panel Controls & Indicators (RM-704)

- (1) Panel / headset mic switch
- (1) Mic on button
- (1) All talk button
- (1) Announce button
- (4) Program
- ON-OFF-INTERRUPT
- DIP switches
- (1) Program level control
- (4) Listen adjust controls
- (4) Channel null adjust controls
- (4) Channel program feed adjust controls
- (4) Talk buttons
- (4) Call buttons
- (4) Listen buttons
- (1) Speaker ON-OFF switch
- (1) Speaker volume control
- (1) Panel mic gain control
- (1) Sidetone adjust control
- (1) Headset audio limiter DIP switch

- (3) Interrupt enable DIP switches
- (4) Auto-call DIP switches
- (4) Auto-talk/listen DIP switches
- (4) Talk latch disable DIP switches
- (4) Line length DIP switches

**Environmental**

32 - 122° F (0 - 50° C)

**Dimensions (MS-704/RM-704)**

19 in. W x 3.5 in. H x 10.5 in. D  
(483 mm x 88 mm x 267 mm)

**Weight**

MS-704

10.86lbs. (4.94 kg)

RM-704

10.07lbs. (4.58kg)

**Notice About Specifications**

While Clear-Com makes every attempt to maintain the accuracy of the information contained in its product manuals, that information is subject to change without notice. Performance specifications included in this manual are design-center specifications and are included for customer guidance and to facilitate system installation. Actual operating performance may vary.



# LIMITED WARRANTY

Vitec Group Communications (VGC) warrants that at the time of purchase, the equipment supplied complies with any specification in the order confirmation when used under normal conditions, and is free from defects in workmanship and materials during the warranty period.

During the warranty period VGC, or any service company authorized by VGC, will in a commercially reasonable time remedy defects in materials, design, and workmanship free of charge by repairing, or should VGC in its discretion deem it necessary, replacing the product in accordance with this limited warranty. In no event will VGC be responsible for incidental, consequential, or special loss or damage, however caused.

*VGC offers 24 x 7 customer support if you have an Extended Warranty or Service Contract.*

*Return Material Authorization (RMA) numbers are required for all returns.*

*Both warranty and non-warranty repairs are available.*

## WARRANTY PERIOD

The product may consist of several parts, each covered by a different warranty period. The warranty periods are:

- Cables, accessories, components, and consumable items have a limited warranty of 90 days.
- Headsets, handsets, microphones, and spare parts have a limited warranty of one year.
- UHF wireless IFB products have a limited warranty of one year.
- UHF wireless intercom systems have a limited warranty of three years.
- All other Clear-Com and Drake brand systems and products, including belt packs, have a limited warranty of two years.

The warranty starts at the time of the product's original purchase. The warranty start date for contracts which include installation and commissioning will commence from the earlier of date of the Site Acceptance Test or three months from purchase.

## TECHNICAL SUPPORT

To ensure complete and timely support to its customers, VGC's User Support Center is staffed by qualified technical personnel. Telephone and email technical support is offered worldwide by the User Support Center.

The User Support Center is available to VGC's customers during the full course of their warranty period. Telephone support during the warranty period will be offered at no charge between 09:00 and 17:00 according to the customer's local time zone.

In addition, for customers who purchase an Extended Warranty or Service Contract, 24-hour customer support is offered immediately upon purchase of

such agreement. For more information, contact your authorized dealer, distributor, or sales representative.

Instructions for reaching VGC's User Support Centers are given below.

**Telephone for Europe, Middle East and Africa:** +49 40 6688 4040

**Telephone for the Americas and Asia:** +1 510 337 6600

**Email:** [vitec.support@AVC.de](mailto:vitec.support@AVC.de)

Once the standard warranty period has expired, the User Support Center will continue to provide telephone support if you have purchased an Extended Warranty or Service Contract. In these cases, you will have access to telephone support 24 hours per day, 7 days per week.

## **WARRANTY REPAIRS AND RETURNS**

Before returning equipment for repair, contact a User Support Center to obtain a Return Material Authorization (RMA). VGC representatives will give you instructions and addresses for returning your equipment. You must ship the equipment at your expense, and the support center will return the equipment at VGC's expense.

For out-of-box failures, use the following contact information:

### **Europe, Middle East and Africa**

Tel: +44 1223 815000 Email: [customerservicesEMEA@vitecgroup.com](mailto:customerservicesEMEA@vitecgroup.com)

### **North America, Canada, Mexico, Caribbean & US Military**

Tel: +1 510 337 6600 Email: [customerservicesUS@vitecgroup.com](mailto:customerservicesUS@vitecgroup.com)

### **Asia Pacific & South America**

Tel: +1 510 337 6600 Email: [customerservicesAPAC@vitecgroup.com](mailto:customerservicesAPAC@vitecgroup.com)

VGC has the right to inspect the equipment and/or installation or relevant packaging.

## **NON-WARRANTY REPAIRS AND RETURNS**

For items not under warranty, you must obtain an RMA by contacting the User Support Center. VGC representatives will give you instructions and addresses for returning your equipment.

You must pay all charges to have the equipment shipped to the support center and returned to you, in addition to the costs of the repair.

## **EXTENDED WARRANTY**

If you purchase an Extended Warranty, you are also given access free of charge to the User Support Center 24 hours a day, 7 days a week.

You can purchase an extended warranty at any time during the first two years of ownership of the product. The purchase of an extended warranty extends to five

years the warranty of any product offered with a standard two-year warranty. The total warranty period will not extend beyond five years. Any purchase of an extended warranty provides 24 x 7 customer support in addition to the warranty immediately upon purchase of the warranty extension.

**Note:** VGC does not offer warranty extensions on UHF wireless intercom systems, or on any product with a 1-year or 90-day warranty.

## **SERVICE CONTRACT**

VGC also offers service contracts that provide 24 x 7 telephone support, advance replacements, training, proactive maintenance, on-site visits, and no charge for repair or replacement of equipment. For more information, contact your authorized dealer, distributor, or sales representative.

## **LIABILITY**

THE FOREGOING WARRANTY IS VGC'S SOLE AND EXCLUSIVE WARRANTY. THE IMPLIED WARRANTY OF MERCHANTABILITY AND FITNESS FOR A PARTICULAR PURPOSE AND ANY OTHER REQUIRED IMPLIED WARRANTY SHALL EXPIRE AT THE END OF THE WARRANTY PERIOD. THERE ARE NO OTHER WARRANTIES (INCLUDING WITHOUT LIMITATION WARRANTIES FOR CONSUMABLES AND OTHER SUPPLIES) OF ANY NATURE WHATSOEVER, WHETHER ARISING IN CONTRACT, TORT, NEGLIGENCE OF ANY DEGREE, STRICT LIABILITY OR OTHERWISE, WITH RESPECT TO THE PRODUCTS OR ANY PART THEREOF DELIVERED HEREUNDER, OR FOR ANY DAMAGES AND/OR LOSSES (INCLUDING LOSS OF USE, REVENUE, AND/OR PROFITS). SOME STATES DO NOT ALLOW THE EXCLUSION OR LIMITATION OF INCIDENTAL OR CONSEQUENTIAL DAMAGES OR THE LIMITATION ON HOW LONG AN IMPLIED WARRANTY LASTS, SO THE ABOVE LIMITATIONS MAY NOT APPLY TO YOU. IN ANY EVENT, TO THE MAXIMUM EXTENT PERMITTED UNDER APPLICABLE LAW, VGC'S LIABILITY TO CUSTOMER HEREUNDER SHALL NOT UNDER ANY CIRCUMSTANCES EXCEED THE COST OF REPAIRING OR REPLACING ANY PART(S) FOUND TO BE DEFECTIVE WITHIN THE WARRANTY PERIOD AS AFORESAID.

This warranty does not cover any damage to a product resulting from cause other than part defect and malfunction. The VGC warranty does not cover any defect, malfunction, or failure caused beyond the control of VGC, including unreasonable or negligent operation, abuse, accident, failure to follow instructions in the manual, defective or improperly associated equipment, attempts at modification and repair not approved by VGC, and shipping damage. Products with their serial numbers removed or defaced are not covered by this warranty.

This warranty does not include defects arising from installation (when not performed by VGC), lightning, power outages and fluctuations, air conditioning failure, improper integration with non-approved components, defects or failures

of customer furnished components resulting in damage to VGC provided product.

This limited warranty is not transferable and cannot be enforced by anyone other than the original consumer purchaser.

This warranty gives you specific legal rights and you may have other rights which vary from country to country.