

HIGH END SYSTEMS

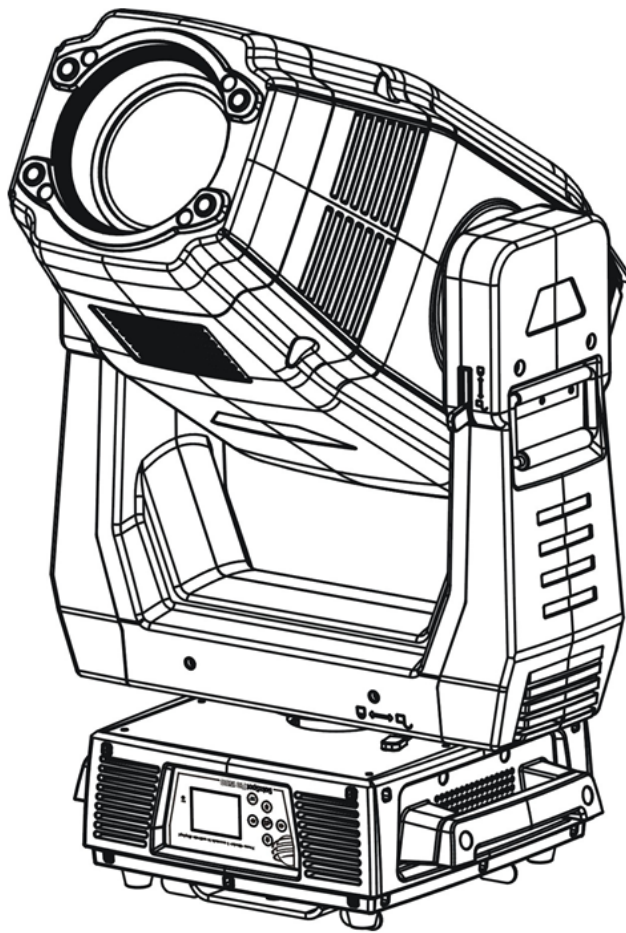

an ETC. Company

User Manual



**SolaSpot 2000**

Version 1.1 -- Revision A

**This page intentionally left blank to ensure new chapters start on right (odd number) pages.**

# Contents

Contents .....	C
Welcome .....	5
Contacting High End Systems® .....	6
Patents .....	10
Terms and Conditions and Warranty Information .....	11
Important Safety Information .....	12
Fixture Overview .....	13
Features .....	15
TECHNICAL SPECIFICATIONS .....	16
Safety Considerations .....	17
General Guidelines .....	19
Installation Instructions .....	20
Dimensional Drawings .....	21
Mounting Orientations .....	22
Linking Fixtures .....	23
DMX Start Address .....	25
Fixture Control Board .....	26
Control Board Functions .....	28
Preset Programming and Playback .....	40
DMX Control Protocol .....	45
Error Codes .....	51

**This page intentionally left blank to ensure new chapters start on right (odd number) pages.**

# Welcome

## Notice

© High End Systems, 2017, All Rights Reserved

Information and specifications in this document are subject to change without notice. High End Systems assumes no responsibility or liability for any errors or inaccuracies that may appear in this manual. Trademarks used in this text: High End Systems, Wholehog, and Lithopatterns, and intellaspot are registered trademarks. Internal Effects, the High End Systems globe logo and the Hog logo are trademarks of High End Systems, Inc. Belden is a registered trademark of Belden, Inc.

Other trademarks and trade names may be used in this document to refer to either the entities claiming the marks and names or their products. High End Systems disclaims any proprietary interest in trademarks and trade names owned by others.

## Contacting High End Systems ®

---

<b>Sales Department</b>	High End Systems, Inc. 2105 Gracy Farms Lane Austin, TX 78758 USA voice: 512.836.2242 fax: 512.837.5290 Toll Free: 800.890.8989
<b>Customer Service</b>	High End Systems, Inc. 2105 Gracy Farms Lane Austin, TX 78758 USA voice: 800.890.8989 fax: 512.834.9195 toll free: 800.890.8989 email: support@highend.com
<b>World Wide Web</b>	<a href="http://www.highend.com">http://www.highend.com</a>

---



## Declaration of Conformity

**Manufacturer's name:** HAO YEANG ELECTRONIC CO., LTD  
**Manufacturer's address:** No. 109, HaiYong Road, GuanNanYoung Industry Districe, Shiji Town  
DanYu Zone, GuanZhou City, China

**Distributor's name:** High End Systems, Inc.  
**Distributor's address:** 2105 Gracy Farms Lane  
Austin, Texas 78758 USA

**Product Name:** SOLASPOT 2000  
**Product Options:** All

*We hereby declare that the above referenced product complies with the essential requirements of Council Directives 2014/30/EU (EMC), 2014/35/EU (LVD) and 2011/65/EC (RoHS) .*

**Safety:** EN 60598-1: 2015  
EN 60598-2-17: 1989 A2: 1991  
EN62493 (2015)  
EN62471 (2008)  
EN61347-2-13: 2014;  
EN61347-1: 2015  
EN62031: 2008+A1; 2013+A2: 2015

**EMC:** Emission: EN55015:20013+A1:2015,  
EN61547:2009  
EN 61000-3-2 (2014)  
EN 61000-3-3 (2013)

<b>ROHS:</b>	<b>Restricted Substances</b>	<b>Maximum Concentration Value (by weight in homogeneous material)</b>
	Cadmium (Cd)	0.01%
	Lead (Pb)	0.1%
	Mercury (Hg)	0.1%
	Hexavalent Chromium (Cr VI)	0.1%
	Polybrominated Biphenyl (PBB)	0.1%
	Polybrominated Diphenyl Ethers (PBDE)	0.1%

Kenneth S. Hansen



Compliance Engineer

July 10 2017



## **FCC Information**

This equipment has been tested and found to comply with the limits for a Class A digital device, pursuant to part 15 of the FCC rules. These limits are designed to provide reasonable protection against harmful interference when the equipment is operated in a commercial environment. This equipment generates, uses, and can radiate radio frequency energy and, if not installed and used in accordance with the instruction manual, may cause harmful interference to radio communications. Operation of this equipment in a residential area is likely to cause harmful interference, in which case the user will be required to correct the interference at his own expense.

## Patents

---

### **NOTICE OF INTELLECTUAL PROPERTY RIGHTS**

For a listing of current patents go to the web address:

<https://www.highend.com/patents>

---

## Terms and Conditions and Warranty Information

---

Complete Terms and Conditions and Warranty information can be found on the website <https://www.highend.-com/pub/products/HES-Warranty-Information.pdf>.

---

### Product Modification Warning

High End Systems products are designed and manufactured to meet the requirements of United States and International safety regulations. Modifications to the product could affect safety and render the product non-compliant to relevant safety standards.

#### **Mise En Garde Contre La Modification Du Produit**

Les produits High End Systems sont conçus et fabriqués conformément aux exigences des règlements internationaux de sécurité. Toute modification du produit peut entraîner sa non conformité aux normes de sécurité en vigueur.

#### **Produktmodifikationswarnung**

Design und Herstellung von High End Systems entsprechen den Anforderungen der U.S. Amerikanischen und internationalen Sicherheitsvorschriften. Abänderungen dieses Produktes können dessen Sicherheit beeinträchtigen und unter Umständen gegen die diesbezüglichen Sicherheitsnormen verstoßen.

#### **Avvertenza Sulla Modifica Del Prodotto**

I prodotti di High End Systems sono stati progettati e fabbricati per soddisfare i requisiti delle normative di sicurezza statunitensi ed internazionali. Qualsiasi modifica al prodotto potrebbe pregiudicare la sicurezza e rendere il prodotto non conforme agli standard di sicurezza pertinenti.

#### **Advertencia De Modificación Del Producto**

Los productos de High End Systems están diseñados y fabricados para cumplir los requisitos de las reglamentaciones de seguridad de los Estados Unidos e internacionales. Las modificaciones al producto podrían afectar la seguridad y dejar al producto fuera de conformidad con las normas de seguridad relevantes.

## Important Safety Information

Instructions pertaining to continued protection against fire, electric shock, and injury to persons are found throughout this manual. Please read all instructions prior to assembling, mounting, and operating this equipment.

The following international caution and warning symbols appear in margins throughout this manual to highlight messages.



**This symbol appears adjacent to Caution messages. Not heeding these messages could result in personal injury and/or damage to equipment.**



**This symbol appears adjacent to high voltage warning messages. Not heeding these messages could result in serious personal injury.**



**This symbol cautions against mounting the fixture on or near a flammable surface.**



**This symbol indicates that, while operating, equipment surfaces may reach very high temperatures. Allow the fixture to cool before handling.**

# Fixture Overview

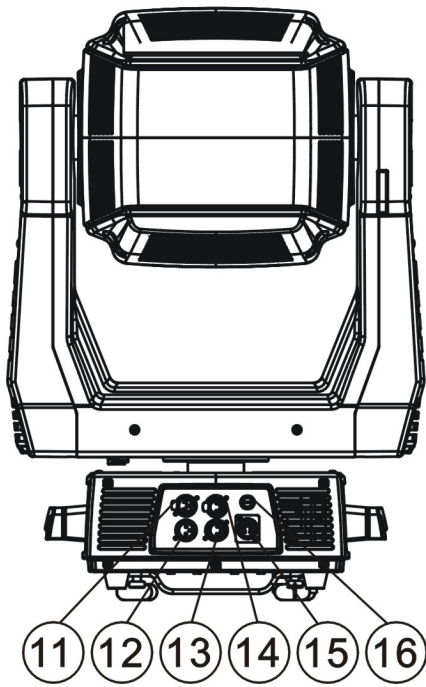
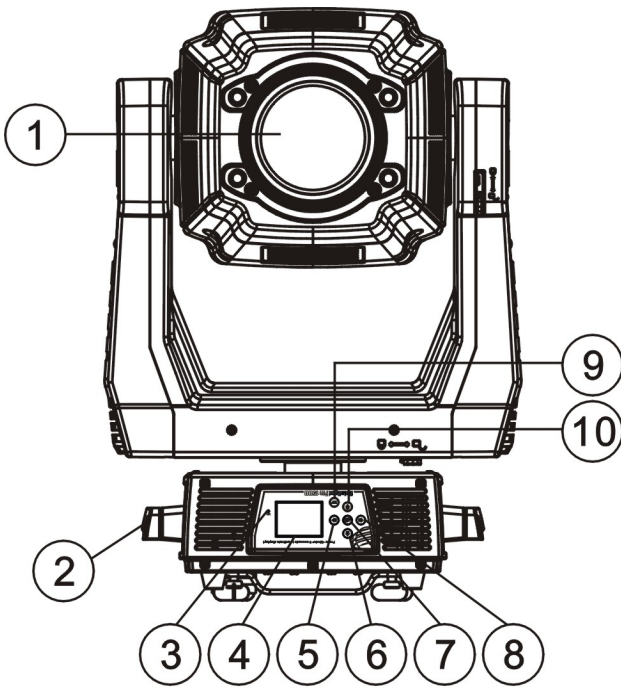

1: Lens
2: Handle
3: Microphone
4: Display
5: Left-button
6: Down-button
7: ENTER-button
8: Right-button
9: Mode/Esc-button
10: Up-button
11: 5-Pin DMX out
12: 5-Pin DMX in
13: 3-Pin DMX in
14: 3-Pin DMX out
15: Power supply
16: Fuse

**This page intentionally left blank to ensure new chapters start on right (odd number) pages.**

# Features

- LED: Atria HL600-A
- DMX Channels mode: 43 channels
- Stand alone operation with Master/Slave function, sound activated via built in microphone.
- Pan and tilt movement: 8 and 16 bit resolution, for smooth and precise motion
  - Movement: Pan: 540°
  - Movement: Tilt: 265°
- 6 Position color wheel, plus open white. Two directional rainbow effects
- CMY & CTO Variable Color Mixing for Infinite Color Possibilities
- Rotation gobo: 6 interchangeable, rotating gobos plus open
- Prism and prism rotating functions
- Animation flame effect
- Step-less frost, 0%~100% linear change frost
- Motorized focus
- Strobe/shutter: High speed shutter, 0-13 Hz or random strobe
- Dimmer intensity from 0%~100%
- Zoom - ~8deg - 38deg linear zoom
- Position memory, auto correction after unexpected movement
- Control board with full color LCD graphic display and touch-keyboard
  - Display: Can be changed 180° reverse to fit for different installation position.
  - Internal battery for display and config. Enables users to enter menu for setting start address and other functions.
- Software-upload by optional accessory dongle via DMX line

## TECHNICAL SPECIFICATIONS

- Power supply: AC 100-240V~50/60Hz
- Power consumption: 800W
- Flight case dimensions: 68x55.5x(86.5+15.5)cm
- Net weight:41.5 KGS
- Gross weight: 86.5 KGS



# Safety Considerations



**CAUTION:** The information in this chapter is intended to assist qualified personnel *only*.



**WARNING:** Disconnect power before servicing. Replace fuses with the specified type and rating only.



**Caution:** Class 2 LED product. LED Radiation. Do not stare into beam.

**Caution:** The fixture should be positioned so that prolonged staring into the fixture at a distance closer than 3 meters is not expected.



This device has left the factory in perfect condition. In order to maintain this condition and to ensure a safe operation, it is absolutely necessary for the user to follow the safety instructions and warning notes written in this user manual.

**Important:**

*Damages caused by the disregard of this user manual are not subject to warranty. The dealer will not accept liability for any resulting defects or problems.*

## **Warnings**

- If the fixture has been exposed to temperature changes due to environmental changes, do not switch it on immediately. The condensation that could form could cause internal damage. Leave the fixture switched off until it has reached room temperature.
- This fixture falls under protection-Class I. Therefore it is essential that the device be earthed.
- The electrical connection must carry out by a qualified person.
- Make sure that the available voltage is within stated range.
- Make sure the power cord is never crimped or damaged by a sharp edge. Replace cable immediately if damaged, this work must be done by an authorized dealer.
- Always disconnect from power, when the device is not in use or before cleaning it. Only handle the power cord by the plug. Never pull out the plug by tugging the power cord.
- Don't project the beam onto combustible substances, this could cause a safety hazard and/or start a fire.
- Please be aware that damages caused by modifications to the fixture will void warranty.
- Keep away from children and non-professionals.
- Maintenance should be performed by a qualified individual.
- There are no serviceable parts inside the device. The following points have to be considered when inspecting the fixture for maintenance:
- All screws for installing the devices or parts of the device have to be tightly connected and must not be corroded.
- Mechanically moved parts must not show any traces of wear and must not rotate freely without unbalance.
- The electric power supply cables must not show any damage, material fatigue or excessive dirt.

## General Guidelines

- This device is a lighting effect for professional use on stages, theaters, or other professional installations, etc., the device was designed for indoor use only.
- This fixture is only allowed to be operated with the max alternating current (AC Voltage) which stated in the technical specifications printed on the fixture.
- Lighting effects are not designed for permanent operation. Operation breaks ensure that the device will perform longer without failure
- Do not shake the device. Avoid brute force when installing or operating the device.
- While choosing the installation-spot, please make sure that the device is not exposed to extreme heat, moisture or dust. Please don't project the beam onto combustible substances. The minimum distance between light-output from the projector and the illuminated surface must be more than 0.5 meter or 1.6 ft.
- If you use the quick-lock cam to hang this fixture, be sure to properly insert the fasteners in the quick lock holes correctly. Do not hang this fixture without a safety cable.
- Operate the device only after having familiarized with its functions. Do not permit operation by unqualified persons, damages can occur due to unprofessional operation.
- Please use the original packaging if the device is to be transported.
- For safety reasons, please be aware that all modifications on the device are forbidden.
- If this device will be operated in any way different to the one described in this manual, the product may suffer damages and the warranty becomes void. Furthermore, misuse may lead to short-circuit, burns, electric shock, lamp explosion, crash, and other damage to the fixture or persons.

# Installation Instructions

- The installation must always be secured with a secondary safety attachment, e.g. an appropriate safety cable.
- Never stand directly below the device when mounting, removing or servicing the fixture.
- The operator has to make sure the safety and technical installations are approved by an expert before taking using this fixture in the field for the first time.
- Fixed installations must be inspected by a skilled person on a regular basis.
- Overhead mounting requires extensive experience, including amongst others calculating working load limits, installation material being used, and periodic safety inspection of all installation material and the device. If you lack these qualifications, do not attempt the installation yourself. Improper installation can result in serious bodily injury.

## Attachment Instructions

- Attach the Omega clamp on the bracket by tighten the M12 bolt on the bracket to the hole in the middle of the bracket.
- Insert the quick-lock fasteners of the bracket into the respective holes on the bottom of the fixture.
- Tighten the quick-lock fasteners fully clockwise.
- Install the second Omega clamp.
- Attach the safety-cable through the holes on the bottom of the base. Attach to the trussing system or other safe fixation point.
- Be sure the safety is fully looped, the quick-link is attached and fully tighten
- Inspect for complete attachment before lifting over-head

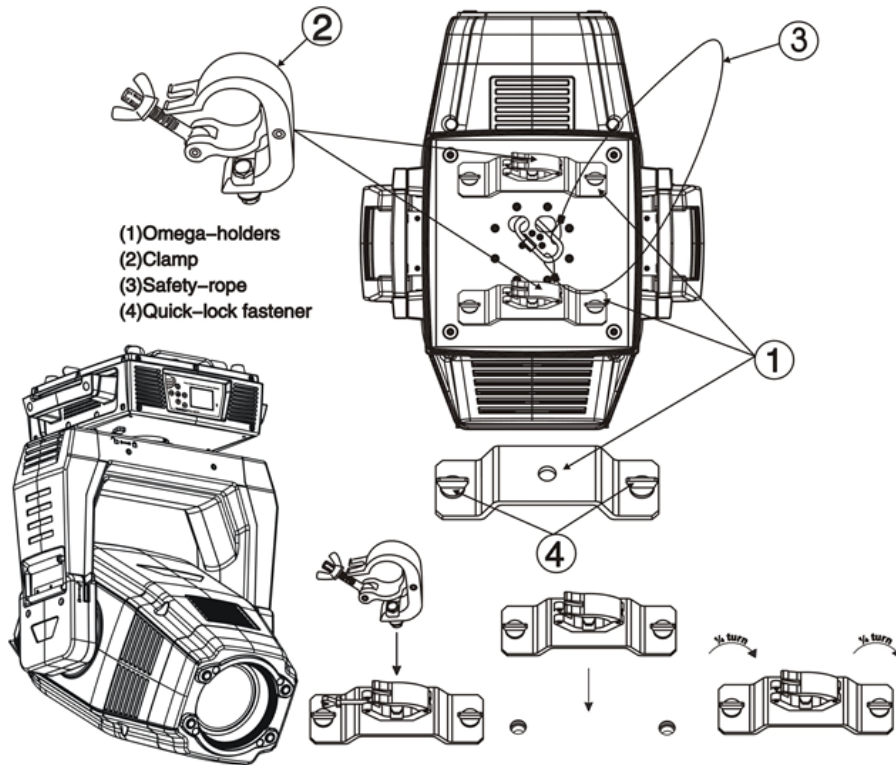

# Dimensional Drawings

Dims listed are mm and (inches)

## Dimensional Drawings:

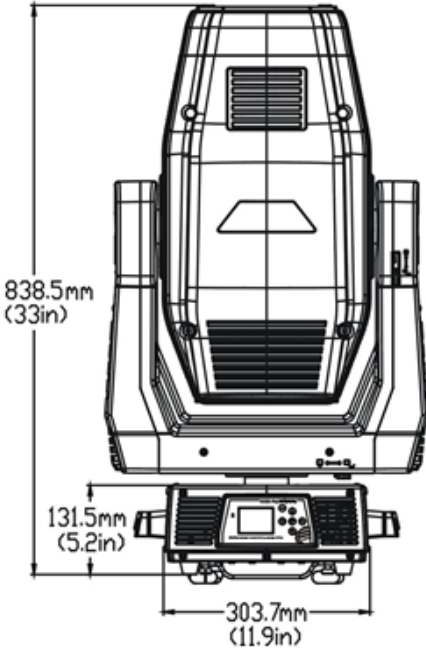
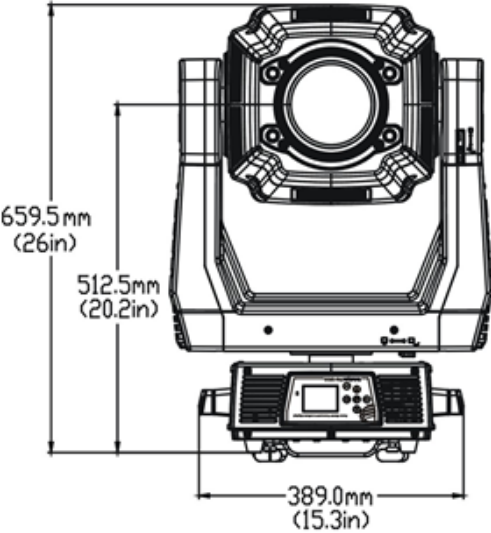
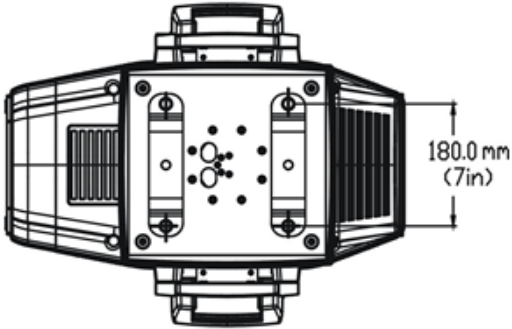
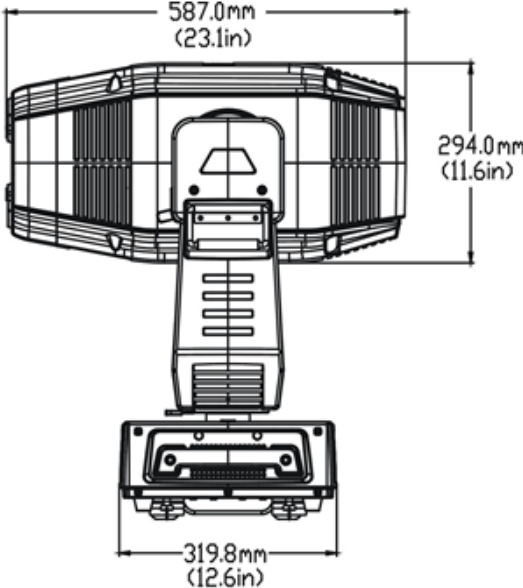

# Mounting Orientations

Be sure this fixture is kept at least 0.5m (1.6ft) away from any flammable materials (decoration etc.). Always use and install the supplied safety cable as a safety measure to prevent accidental damage and/or injury in the event the clamp is improperly installed or fails.

Overhead mounting requires extensive experience, including amongst others calculating working load limits, a detailed knowledge of the installation materials being used, and periodic safety inspection. This safety inspection must cover all installation material, trussing, hardware and the fixture. If you lack these qualifications, do not attempt the installation yourself. Improper installation can result in severe injury and possible death if struck by a falling fixture.

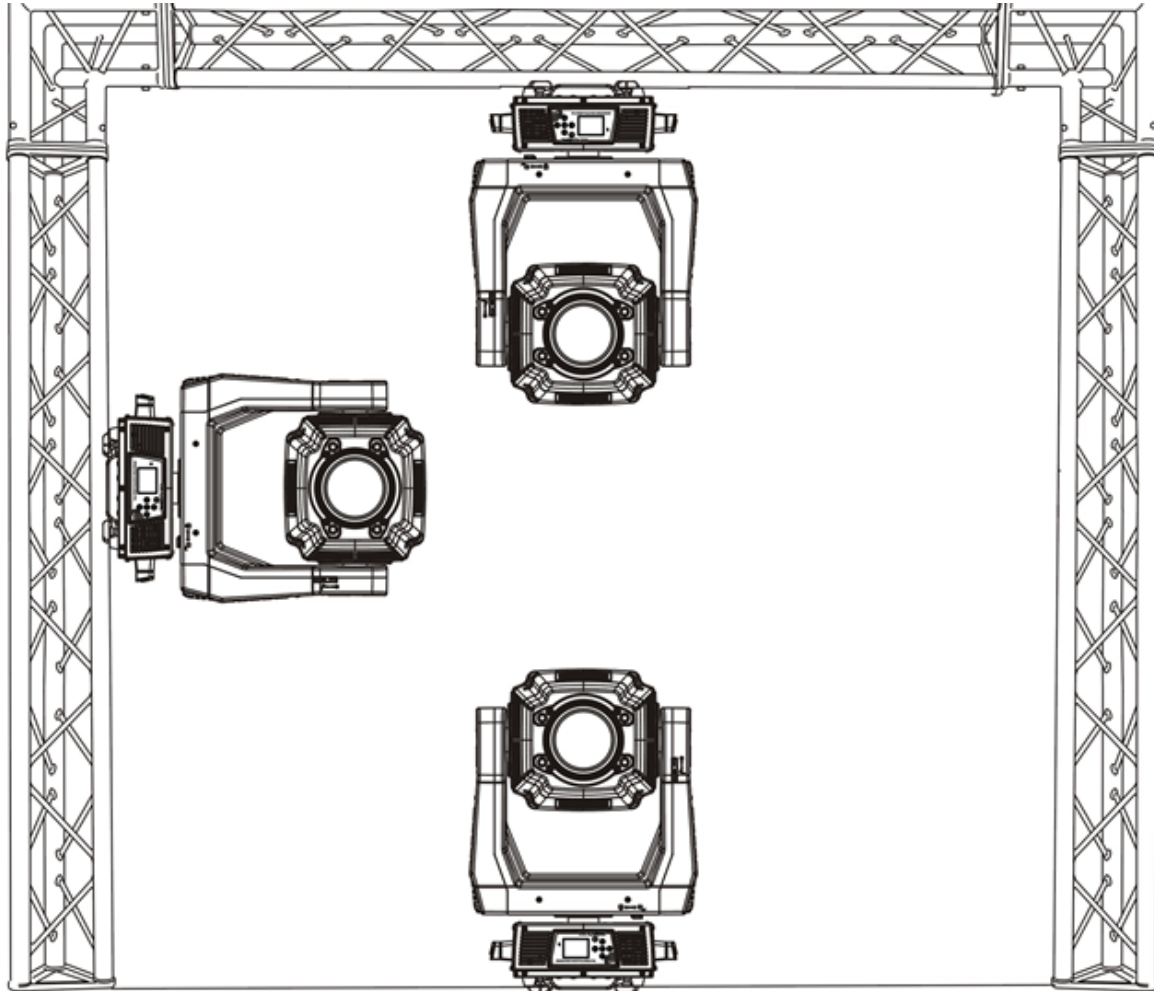

# Linking Fixtures

The SolaSpot 2000 fixture operates on standard DMX512 link controlled by a DMX console. The number of fixtures on a link will be determined by the combined number of channels required by all the fixtures. A SolaSpot 2000 fixture requires a 43 channel footprint on a standard DMX512 link. Attach the fixture to the link using data-grade cable and 5-pin or 3-pin XLR cable connectors

## Cable Connectors

The SolaSpot 2000 fixture accepts both 3-pin and 5-pin XLR cable connectors. Cabling must have a male XLR connector on one end of the cable and a female XLR connector on the other end.

**Note:** Pins four and five of a 5-pin cable connector are not used, but they allow a secondary data link to pass through the fixture.

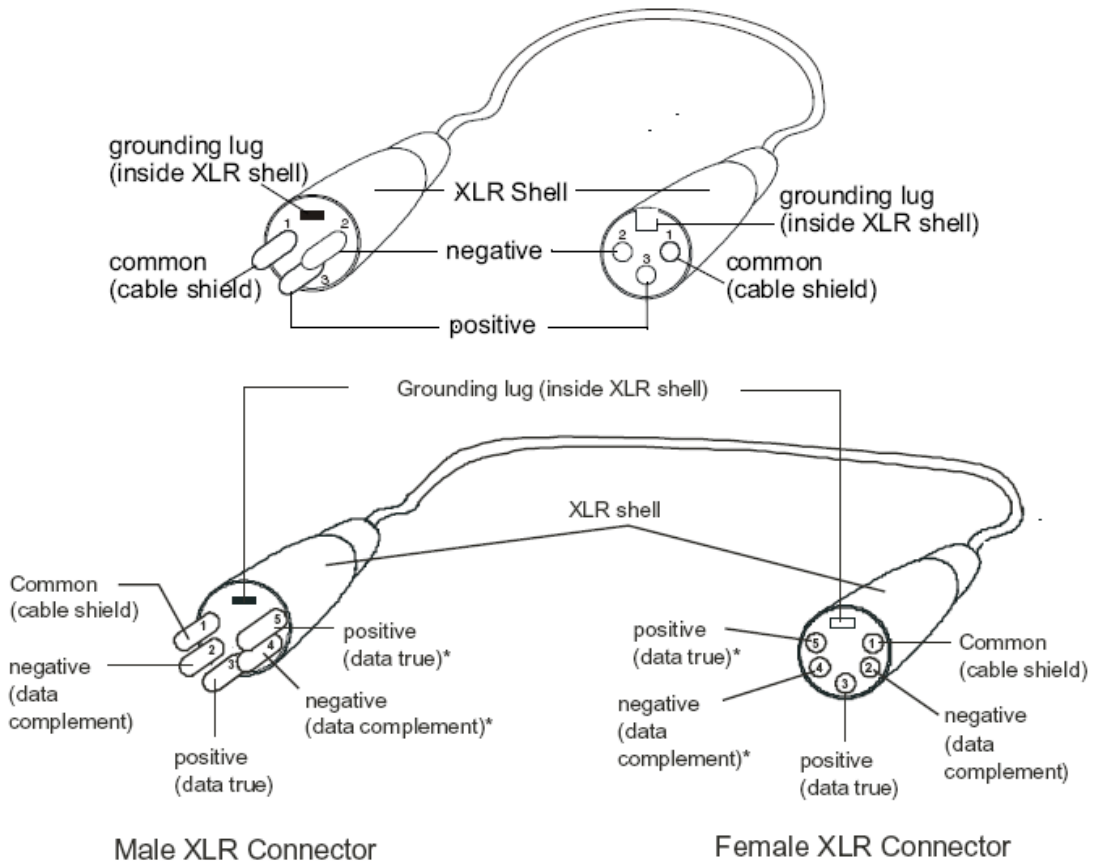

\*This data line is not used by the fixture, but allows data to pass through the fixture.

## Connecting to the Link

To link one or more fixtures to a DMX controller:

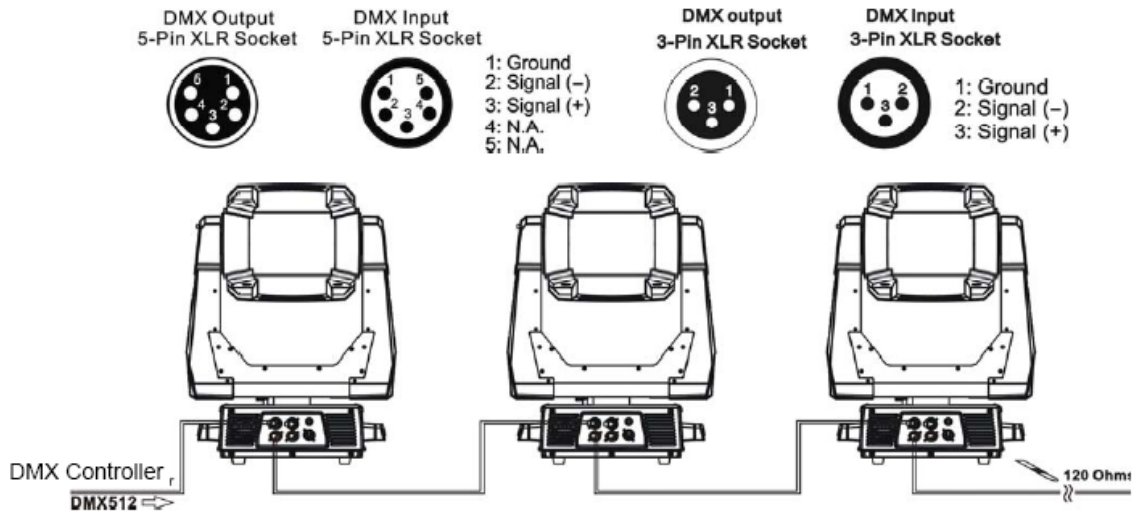

- Connect the male XLR connector of a DMX Data cable to the controller's DMX Data Out connector.
- Connect the Data cable's female XLR connector to the Data In connector of the first (or next) fixture on the DMX link.
- Continue linking the remaining fixtures connecting a cable from the Data Out connector of each fixture to the Data In connector of the next fixture on the link.

## DMX Termination

For installations where the DMX cable has to run a long distance or is in an electrically noisy environment, a DMX terminator on the last fixture of the link prevents data reflection, which can corrupt the data communication on the link.

Terminate the link by installing a 120 ohm, 1/4 watt (minimum) terminator in the fixture's Data Out (female) cable connector in the last fixture on each DMX link.

To construct a terminator:

1. Disassemble a male 3-pin or 5-pin XLR connector.
2. Solder a 120 ohm resistor, minimum of 1/4 watt, between Pin 2 and Pin 3.
3. Reassemble the XLR connector.

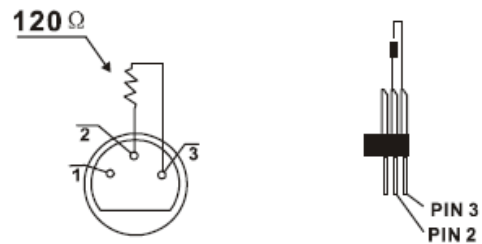



# DMX Start Address

All fixtures should be given a unique DMX starting address when using a DMX signal, so that the correct fixture responds to the correct control signals. This DMX start address is the channel number from which the fixture starts to “listen” to the digital control information sent out from the DMX controller. The setting of this start address is achieved by setting the correct number on the display located on the base of the device.

You can set the same starting address for all fixtures or a group of fixtures, or make use different addresses for each fixture individually.

If you set the same address, all the units will start to “listen” to the same control signal from the same channel number. In other words, changing the settings of one channel will affect all the fixtures simultaneously.

If you set a different address, each unit will start to “listen” to the channel number you have set, based on the quantity of control channels of the unit. That means changing the settings of one channel will affect only the selected fixture.

In the case of this fixture, which is a 43 channel fixture, you should set the starting address of the first unit to 1, the second unit to 44 ( $43 + 1$ ), the third to 87 ( $44 + 43$ ), and so on.

# Fixture Control Board

The Control Board offers several features: you can simply set the starting address , run the pre-programmed program or make other changes.

The main menu is accessed by pressing the **[Mode / Esc]** button until the display is visible.

Browse through the menu by pressing the **[UP]** button ,**[Down]** button , **[Left]** button or **[Right]** button.

Press the **[Enter]** button in order to select the desired menu.

You can change the selection by pressing the directional buttons, i.e. the **[UP]** button ,**[Down]** button , **[Left]** button or **[Right]**.

Confirm every selection by pressing the **[Enter]**.

You can leave every mode by pressing the **[Mode / Esc]** button.

The functions provided are described in the following sections. The menu item will disappear after 10 seconds after the last key press. The functions provided are described in the following sections.

<b>Address</b>	A001~Axxx			DMX address setting
<b>Info</b>	Time Info.	Current Time Ttl Life Hrs Last Run Hrs LED Hours Timer PIN Clr Last Run LED Time PIN Clen LED Time	XXXX(Hours) XXXX(Hours) XXXX(Hours) XXXX(Hours) Password=XXX ON/OFF Password=XXX ON/OFF	Power on running time Fixture running time Fixture Last times clear LED running time Timer Password 038 Clear Fixture Last time LED Password ="038" Clear LED time
	Value Disp.	NONE ALL, PAN.....		MDX Mode Select DMX value display
	Head Temp.	XXX°C/°F		Temperature in the head
	Fan Speed	FAN 1:XX RPM FAN 2:XX RPM FAN 3:XX RPM FAN 4:XX RPM		Fan Information
	Software Ver	Ver x.x.x		Software version

Set	Status	No DMX Mode Pan Reverse Tilt Reverse Pan Degree Encoders Pan/Tilt Spd Mic Sens. Hibernation	Close/Hold/Auto/Music ON/OFF ON/OFF 630/540 ON/OFF Speed 1~ 4 0~99% OFF, 01M~99M, 15M	Add. via DMX Pan Reverse movement Tilt Reverse movement Pan Degree Select Movement Mode Select Movement Feedback Sensitivity of Mic. Standby Mode
	Service PIN	Service PIN RDM PID	Password=XXX xxxxxx	Service Password"=050" RDM PID Code
	Disp. Setting	ShutoffTime Flip Display Key Lock	02~60m 05m ON/OFF ON/OFF	Display shutofftime Reverse 180 degree Key Lock
	Temp. C/F	Fahrenheit Celsius		Temperature switch between °C/°F
	Reset Default	ON/OFF		Restore factory set.
Test	Home	All Pan & Tilt Colors Gobos Others		Reset All Reset Pan & Tilt Reset Colors Reset Gobos Reset Others
	Test Channel	PAN .....		Test function
	Manual Ctrl.	PAN =XXX :		Fine adjustment of the LED
	Calibration	-Password- Pan =XXX :		Password "050" Calibrate and adjust the effects to standard/right position
Preset	Select Prog.	Prog. Part 1 = Program 1 ~ 10 Prog. Part 2 = Program 1 ~ 10 Prog. Part 3 = Program 1 ~ 10	Program 1 Program 2 Program 3	Select programs to be run
	Edit Prog.	Program 1 : Program 10	Program Test Step 01=SCxxx Step 64=SCxxx	Testing program Program in loop Save and exit
	Edit Scenes	Edit Scene 001 ~ Edit Scene 250	Pan, Tilt,..... --Fade Time-- --Scene Time-- Input By Outside	Save and automatically return manual scenes edit
	Scenes Input	XX~XX		Automat. scenes rec

# Control Board Functions

## Address

With this function, you can adjust the desired DMX start address via the Control Board.

1. Access the main menu.
2. Tap the <Up/Down>button until "Address" is displayed.
3. Press ENTER, the display will show "Address".
4. Tap the <Up/Down>button, the display will show "A001~AXXX"
5. Press ENTER to confirm or press <MODE/ESC> to return to the main menu

## Time Info

### Current Time

With this function, you can display the running time from last power on. The display shows "XXXX", "XXXX" stands for the number of hours. The counter is reset after power-off.

1. Tap <MODE/ESC> button, access the main menu.
  - Tap the <Up/Down>button until "Info" is displayed. Press ENTER, the display will show "Info".
  - Tap the <Up/Down>button until the display will show "Time Info".
  - Press ENTER, the display will show "Time Info".
2. Press <Up/Down>, the display will show "Current Time".
3. Press< ENTER>, the display will show "Current Time".
4. The display will show "XXXX" (Hours) ;
5. Press <ENTER> to confirm or press <MODE/ESC> to return to the main menu.

### Ttl Life Hrs

With this function, you can display the total running time of the fixture. The display shows "XXXX", "XXXX" stands for the number of hours.

1. Tap <MODE/ESC> button, access the main menu.
  - Tap the <Up/Down>button until "Info" is displayed. Press ENTER, the display will show "Info".
  - Tap the <Up/Down>button until the display will show "Time Info".
  - Press ENTER, the display will show "Time Info".
2. Press <Up/Down>, the display will show "Ttl Life Hrs".
3. Press< ENTER>, the display will show "Ttl Life Hrs".
4. The display will show "XXXX" (Hours) ;
5. Press <ENTER> to confirm or press <MODE/ESC> to return to the main menu.

### Last Run Hrs

With this function, you can display the last running time of the fixture. The display shows "XXXX", "XXXX" stands for the number of hours.

1. Tap <MODE/ESC> button, access the main menu,

- Tap the <Up/Down>button until "Info" is displayed. Press ENTER, the display will show "Info."
  - Tap the <Up/Down>button until the display will show "Time Info."
  - Press ENTER, the display will show "Time Info."
2. Press <Up/Down>, the display will show "Last Run Hrs".
  3. Press< ENTER>, the display will show "Last Run Hrs".
  4. The display will show "XXXX" (Hours) ;
  5. Press <ENTER> to confirm or press <MODE/ESC> to return to the main menu.

### **LED Hrs**

With this function, you can display total running time of the LED. The display shows "XXXX", "XXXX" stands for the number of hours.

1. Tap <MODE/ESC> button, access the main menu.
  - Tap the <Up/Down>button until "Info" is displayed. Press ENTER, the display will show "Info."
  - Tap the <Up/Down>button until the display will show "Time Info."
  - Press ENTER, the display will show "Time Info."
2. Press <Up/Down>, the display will show "LED Hours".
3. Press< ENTER>, the display will show "LED Hours".
4. The display will show "XXXX" (Hours) ;
5. Press <ENTER> to confirm or press <MODE/ESC> to return to the main menu.

### **Timer PIN**

With this function, you can display the timer password. The time password is 038.

1. Tap <MODE/ESC> button, access the main menu.
  - Tap the <Up/Down>button until "Info" is displayed. Press ENTER, the display will show "Info."
  - Tap the <Up/Down>button until the display will show "Time Info."
  - Press ENTER, the display will show "Time Info."
2. Press <Up/Down>, the display will show "Timer PIN".
3. Press< ENTER>, the display will show "Timer PIN", the time password is 038.
4. Press <ENTER> to confirm or press <MODE/ESC> to return to the main menu.

### **Clr Last Run**

With this function, you can clear last run time of the fixture. The display shows "OFF" or "ON", Press "Enter" to confirm.

1. Tap <MODE/ESC> button, access the main menu.
  - Tap the <Up/Down>button until "Info" is displayed. Press ENTER, the display will show "Info."
  - Tap the <Up/Down>button until the display will show "Time Info."
  - Press ENTER, the display will show "Time Info."
2. Press <Up/Down>, the display will show "Clr Last Run".
3. At "Timer Password" menu input a correct password, press< ENTER>, the display will show "Clr Last Run",
4. The display will show "OFF" or "ON".
5. Press <ENTER> to confirm or press <MODE/ESC> to return to the main menu.

### **Timer PIN**

With this function, you can display the timer password. The time password is 038.

1. Tap <MODE/ESC> button, access the main menu.
  - Tap the <Up/Down>button until "Info" is displayed. Press ENTER, the display will show "Info".
  - Tap the <Up/Down>button until the display will show "Time Info".
  - Press ENTER, the display will show "Time Info".
2. Press <Up/Down>, the display will show "LED Time PIN".
3. Press< ENTER>, the display will show "LED Time PIN", the time password is 038.
4. Press <ENTER> to confirm or press <MODE/ESC> to return to the main menu.

### **Clean LED Time**

With this function, you can clear the running time of the LED engine (this should not be done unless an engine has been replaced)

1. Tap <MODE/ESC> button, access the main menu.
  - Tap the <Up/Down>button until "Info" is displayed. Press ENTER, the display will show "Info".
  - Tap the <Up/Down>button until the display will show "Time Info".
  - Press ENTER, the display will show "Time Info".
2. Press <Up/Down>, the display will show "Clean LED Time".
3. At "Timer Password" prompt, input a correct password, press< ENTER>, the display will show "Clean LED Time",
4. The display will show "Off" or "On"
5. Press <ENTER> to confirm or press <MODE/ESC> to return to the main menu.

### **Value Displayed**

#### **NONE**

With this function, you can choose to turn off display of DMX Control channel values.

1. Tap <MODE/ESC>button, access the main menu,
  - Tap the <Up/Down>button until "Info" is displayed.
  - Press ENTER, the display will show "Info".
2. Press <Up/Down>, the display will show "Value Disp".
3. Press< ENTER>, the display will show "Value Disp".
4. The display show "None".
5. Press <ENTER> to confirm or press <MODE/ESC> to return to the main menu.

#### **ALL, PAN**

With this function you can display the DMX 512 value of each channel. If all is selected, the display will automatically show a channel that is changing.

1. Tap <MODE/ESC> button, access the main menu,
  - Tap the <Up/Down>button until "Info" is displayed.
  - Press ENTER, the display will show "Info".
2. Tap the <Up/Down>button until "Value Disp" is displayed.
3. Press ENTER, the display will show "Value Disp".
4. Tap the <Up/Down> button, choose each channel.
5. Press ENTER to confirm or press <MODE/ESC> to return to the main menu.

### **Head Temp.**

With this function you can display the temperature on the display board of the base (near CMY-filter) in Celsius.

1. Tap <MODE/ESC> button, access the main menu.
  - Tap the <Up/Down>button until "Info" is displayed.
  - Press ENTER, the display will show "Info".
2. Press <Up/Down>, the display will show "Head Temp."
3. Press< ENTER>, the display will show "Head Temp."
4. The display show "XXX °C/ °F".
5. Press <ENTER> to confirm or press <MODE/ESC> to return to the main menu.

### **Fan Speed**

With this function you can display the RPM of various fans inside the fixture.

1. Tap <MODE/ESC> button, access the main menu.
  - Tap the <Up/Down>button until "Info" is displayed.
  - Press ENTER, the display will show "Info".
2. Press <Up/Down>, the display will show "Fan Speed."
3. Press< ENTER>, the display will show "Fan 1: xxx RPM", Fan 2: xxx RPM" ...."
4. Press <ENTER> to confirm or press <MODE/ESC> to return to the main menu.

### **Software Ver**

With this function, you can display the software version of the device.

1. Tap <MODE/ESC> button, access the main menu.
  - Tap the <Up/Down>button until "Info" is displayed.
  - Press ENTER, the display will show "Info".
2. Press <Up/Down>, the display will show "Software Ver".
3. Press< ENTER>, the display will show "Software Ver".
4. The display show "Ver x.x".
5. Press <ENTER> to confirm or press <MODE/ESC> to return to the main menu.

### **Set**

#### **Status**

#### **No DMX Mode**

With this function, when DMX is not connected, it runs automatic, closed, hold and music. The default is hold.

1. Tap <MODE/ESC> button, access the main menu.
  - Tap the <Up/Down>button until "Set" is displayed.
  - Press ENTER, the display will show "Set".
  - Tap the <Up/Down>button until the display will show "Status".
  - Press ENTER, the display will show "Status".
2. Press <Up/Down>, the display will show "No DMX Mode".
3. Press< ENTER>, the display will show "No DMX Mode".

4. The display show "Hold", Press <Up/Down>, the display will show "Close", "Auto", "Music".
5. Press <ENTER> to confirm or press <MODE/ESC> to return to the main menu.

### **Pan Reverse**

With this function you can reverse the Pan-movement.

1. Tap <MODE/ESC> button, access the main menu.
  - Tap the <Up/Down>button until "Set" is displayed.
  - Press ENTER, the display will show "Set".
  - Tap the <Up/Down>button until the display will show "Status".
  - Press ENTER, the display will show "Status".
2. Press <Up/Down>, the display will show "Pan Reverse".
3. Press< ENTER>, the display will show "Pan Reverse".
4. The display show "OFF", Press <Up/Down>, the display will show "ON".
5. Press <ENTER> to confirm or press <MODE/ESC> to return to the main menu.

### **Tilt Reverse**

With this function you can reverse the Tilt-movement.

1. Tap <MODE/ESC> button, access the main menu.
  - Tap the <Up/Down>button until "Set" is displayed.
  - Press ENTER, the display will show "Set".
  - Tap the <Up/Down>button until the display will show "Status".
  - Press ENTER, the display will show "Status".
2. Press <Up/Down>, the display will show "Tilt Reverse".
3. Press< ENTER>, the display will show "Tilt Reverse".
4. The display show "OFF", Press <Up/Down>, the display will show "ON".
5. Press <ENTER> to confirm or press <MODE/ESC> to return to the main menu.

### **Encoders**

With this function, you can change the feedback of the pan movement or tilt movement.

1. Tap <MODE/ESC> button, access the main menu.
  - Tap the <Up/Down>button until "Set" is displayed.
  - Press ENTER, the display will show "Set".
  - Tap the <Up/Down>button until the display will show "Status".
  - Press ENTER, the display will show "Status".
2. Press <Up/Down>, the display will show "Encoders".
3. Press< ENTER>, the display will show "Encoders".
4. The display show "ON", Press <Up/Down>, the display will show "OFF".
5. Press <ENTER> to confirm or press <MODE/ESC> to return to the main menu.

### **Pan/Tilt Spd**

With this function, you can select modes from 1 to 4.



1. Tap <MODE/ESC> button, access the main menu.
  - Tap the <Up/Down>button until “Set” is displayed.
  - Press ENTER, the display will show “Set”.
  - Tap the <Up/Down>button until the display will show “Status”.
  - Press ENTER, the display will show “Status”.
2. Press <Up/Down>, the display will show “Pan/Tilt Spd”.
3. Press< ENTER>, the display will show “Pan/Tilt Spd”.
4. The display show “Speed 1”, Press <Up/Down>, the display will show “Speed 2”, “Speed 3”, “Speed 4”.
5. Press <ENTER> to confirm or press <MODE/ESC> to return to the main menu.

#### **Mic Sens.**

With this function, the default is 70%, you can select the desired microphone sensitivity from 0 % to 99 %.

1. Tap <MODE/ESC> button, access the main menu.
  - Tap the <Up/Down>button until “Set” is displayed.
  - Press ENTER, the display will show “Set”.
  - Tap the <Up/Down>button until the display will show “Status”.
  - Press ENTER, the display will show “Status”.
2. Press <Up/Down>, the display will show “Mic Sens.”.
3. Press< ENTER>, the display will show “Mic Sens.”.
4. The display show “70%”, Press <Up/Down>, the display will show “0~99%”.
5. Press <ENTER> to confirm or press <MODE/ESC> to return to the main menu.

#### **Hibernation ——Standby mode**

The lamp and step motors will be power off if the fixture stay without DMX signal for 15 mins (Factory default).The fixture will Home once it receive DMX signal again.

1. Tap <MODE/ESC> button, access the main menu.
  - Tap the <Up/Down>button until “Set” is displayed.
  - Press ENTER, the display will show “Set”.
  - Tap the <Up/Down>button until the display will show “Status”.
  - Press ENTER, the display will show “Status”.
2. Press <Up/Down>, the display will show “Hibernation”.
3. Press< ENTER>, the display will show “Hibernation”.
4. The display show “15M”, Press <Up/Down>, the display will show “01M”, “02M” .... “99M” or “OFF”.
5. Press <ENTER> to confirm or press <MODE/ESC> to return to the main menu.

#### **Service PIN**

**Service PIN**——The Password for this function is “50”.

**RDM PID**—— To take advantage of the technical capabilities of the RDM system, each fixture must have a unique RDM PID, this unique identifying number is used by the controller to manage an individual fixture. There cannot be duplicate RDM PID on the same DMX cable run, this will result in a data collision, and the controller may or may not notify of this issue. Ensure that all fixtures have a unique RDM PID if RDM functionality is to be used.

If DMX splitters are used and RDM control is to be used, these splitters must support RDM.

The number and type of RDM parameters depend on the RDM controller being used.

To Set the RDM PID

Navigate to: Set -> Service Settings -> Service PIN Press <UP> button to select 050 and press <ENTER.>

Navigate to RDM PID: Press the <UP> button to select unique ID's for each fixture and press <ENTER.>

## **Disp.Setting**

### **Shutoff Time**

With this function you can shut off the color LCD display after 2 to 60 minutes. Turn the encoder in order to select the desired shut off time. The default is 2 minute.

### **Flip Display**

With this function you can rotate the display by 180°.

1. Tap <MODE/ESC>button, access the main menu,
  - Tap the <Up/Down>button until "Set" is displayed.
  - Press ENTER, the display will show "Set".
2. Tap the <Up/Down>button until the display will show "Disp.Setting".
3. Press ENTER, the display will show "Disp.Setting".
2. Press <Up/Down>, the display will show "Flip Display".
3. Press< ENTER>, the display will show "Flip Display".
4. The display show "OFF", Press <Up/Down>, the display will show "ON".
5. Press <ENTER> to confirm or press <MODE/ESC> to return to the main menu.

## **Key Lock**

With this function you can activate the automatic keylock status. If this function is activated, the keys will be locked automatically after exiting the edit mode for 15 seconds. Keeping press the <MODE/ESC> key for 3 seconds if you do not need this function.

1. Tap <MODE/ESC> button, access the main menu,
  - Tap the <Up/Down>button until "Set" is displayed.
  - Press ENTER, the display will show "Set".
2. Press <Up/Down>, the display will show "Key Lock".
3. Press< ENTER>, the display will show "Key Lock".
4. The display show "ON", Press <Up/Down>, the display will show "OFF".
5. Press <ENTER> to confirm or press <MODE/ESC> to return to the main menu.

## **Temp. C/F**

With this function, Display the temperature for Celsius or Fahrenheit.

1. Tap <MODE/ESC> button, access the main menu,
  - Tap the <Up/Down>button until "Set" is displayed.
  - Press ENTER, the display will show "Set".
2. Press <Up/Down>, the display will show "Temp. C/F".
3. Press< ENTER>, the display will show "Temp. C/F".
4. The display show "Celsius", Press <Up/Down>, the display will show "Fahrenheit".

5. Press <ENTER> to confirm or press <MODE/ESC> to return to the main menu.

### **ResetDefault**

With this function, you can reset all settings to factory default.

1. Tap <MODE/ESC> button, access the main menu.
  - Tap the <Up/Down>button until "Set" is displayed.
  - Press ENTER, the display will show "Set".
2. Press <Up/Down>, the display will show "ResetDefault".
3. Press< ENTER>, the display will show "ResetDefault".
4. The display show "OFF", Press <Up/Down>, the display will show "ON". (ON = Restore to Factory Default)
5. Press <ENTER> to confirm or press <MODE/ESC> to return to the main menu.

### **Test**

#### **Home**

With this function you can reset the fixture, and reset the Control Boards. You can select the different reset functions by choosing different items in the menu.

1. Tap <MODE/ESC> button, access the main menu.
  - Tap the <Up/Down>button until "Test" is displayed.
  - Press ENTER, the display will show "Test".
2. Tap the <Up/Down>button until the display will show "Home". Press ENTER, the display will show "Home".
3. The display show " All", Press <Up/Down>, the display will show "Pan&Tilt", "Colors", "Shutter", "Others".
4. Press <ENTER> to confirm or press <MODE/ESC> to return to the main menu.

#### **Test Channel**

With this function you can test each channel on its (correct) function.

1. Tap <MODE/ESC> button, access the main menu.
  - Tap the <Up/Down>button until "Test" is displayed.
  - Press ENTER, the display will show "Test".
2. Press <Up/Down>, the display will show "Test Channel".
3. Press< ENTER>, the display will show "Test Channel".
4. The display will show "Pan Moving" first channel, Press <Up/Down>, to choose another channel.
5. Press <ENTER> to confirm or press <MODE/ESC> to return to the main menu.

#### **Manual Ctrl.**

With this function, you can adjust the fixture more easily. All effects will be canceled, the shutter opens and the dimmer intensity will be set to 100 %. With the individual functions, you can focus the light on a flat surface (wall) and perform various fixture adjustments.

1. Tap <MODE/ESC> button, access the main menu.
  - Tap the <Up/Down>button until "Test" is displayed.
  - Press ENTER, the display will show "Test".
2. Press <Up/Down>, the display will show "Manual Ctrl.".
3. Press< ENTER>, the display will show "Manual Ctrl.".

4. The display show "PAN=XXX".
5. Press <ENTER> to confirm or press <MODE/ESC> to return to the main menu.

### **Calibration**

With this function, you can calibrate and adjust the effect wheels to their correct positions. The password is 050.

1. Tap <MODE/ESC> button, access the main menu,
  - Tap the <Up/Down>button until "Test" is displayed.
  - Press ENTER, the display will show "Test".
2. Press <Up/Down>, the display will show "Calibration".
3. Press< ENTER>, the display will show "Calibration".
4. The display show "Password=XXXX".
5. Press <ENTER> to confirm or press <MODE/ESC> to return to the main menu.

### **Preset**

In this menu, user can select different channels list by different sequence:

For example, after the user enter this manual, if select Auto Program = CH 22, means in this User's mode, the "Dimmer" is in Channel 16.

### **PlayBack**

#### **DMX Control**

To set the fixture to be controlled via DMX.

1. Tap <MODE/ESC> button, access the main menu,
  - Tap the <Up/Down>button until "Preset" is displayed. Press ENTER, the display will show "Preset".
  - Tap the <Up/Down>button until the display will show "PlayBack".
  - Press ENTER, the display will show "PlayBack".
2. Tap the <Up/Down>button until "DMX Control" is displayed.
3. Press ENTER, the display will show "DMX Control".
4. Tap the <Up/Down> button, choose each channel.
5. Press ENTER to confirm or press <MODE/ESC> to return to the main menu.

### **Set To Slave**

With this function, you can define the device as slave.

1. Tap <MODE/ESC> button, access the main menu,
  - Tap the <Up/Down>button until "Preset" is displayed. Press ENTER, the display will show "Preset".
  - Tap the <Up/Down>button until the display will show "PlayBack".
  - Press ENTER, the display will show "PlayBack".
2. Tap the <Up/Down>button until "Set To Slave" is displayed.
3. Press ENTER, the display will show "Set To Slave".
4. Tap the <Up/Down> button, the display will show "Slave1", "Slave2", "Slave3".
5. Press ENTER to confirm or press <MODE/ESC> to return to the main menu.

### Auto Program

With this function, you can run the internal program. You can select the desired program under “Select program”. You can set the number of steps under “Edit program”. You can edit the individual scenes under “Edit scenes”. With this function, you can run the individual scenes manually or automatically, with the adjusted Step-Time.

1. Tap <MODE/ESC> button, access the main menu.
  - Tap the <Up/Down> button until “Preset” is displayed. Press ENTER, the display will show “Preset”.
  - Tap the <Up/Down> button until the display will show “PlayBack”. Press ENTER, the display will show “PlayBack”.
2. Tap the <Up/Down> button until “Auto Program” is displayed.
3. Press ENTER, the display will show “Auto Program”.
4. Tap the <Up/Down> button, the display will show “Master1”, “ Alone”.
5. Press ENTER to confirm or press <MODE/ESC> to return to the main menu.

### Music Ctrl.

With this function, you can run the internal program sound-controlled.

1. Tap <MODE/ESC> button, access the main menu. Tap the <Up/Down> button until “Preset” is displayed. Press ENTER, the display will show “Preset”. Tap the <Up/Down> button until the display will show “PlayBack”. Press ENTER, the display will show “PlayBack”.
2. Tap the <Up/Down> button until “Music Ctrl.” is displayed.
3. Press <ENTER>, the display will show “Music Ctrl.”.
4. Tap the <Up/Down> button, the display will show “Master”, “ Alone”.
5. Press <ENTER> to confirm or press <MODE/ESC> to return to the main menu.

### Select Prog.

With this function, you can select the program for the Program Run.

### Edit Prog.

With this function, you can edit the internal programs.

### Edit Scenes

With this function, you can edit the scenes of the internal programs.

### Rec. Controller

This fixture features an integrated DMX-recorder by which you can transmit the programmed scenes from your DMX-controller to the fixture. Adjust the desired scene numbers via the encoder (from – to). When you call up the scenes at your controller, they will automatically be transmitted to the moving head.

### Example:

A Master unit can send up to 3 different data groups to the Slave units, i.e. a Master unit can start 3 different Slave units, which run 3 different programs. The Master unit sends the 3 program parts in a continuous loop.

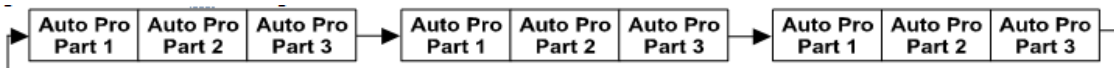

To start a Auto Program please proceed as follows:

#### **1. Slave-Setting:**

- Select "Function Mode" by navigating with the arrow key.
- Press the Enter button to confirm.
- Select "Set to slave" by navigating with the arrow key.
- Press the Enter button to confirm.
- Select "Slave 1", "Slave 2" or "Slave 3".
- Press the Enter button to confirm.
- Press the MODE/ESC button in order to return to the main menu.

#### **2. Automatic Program Run**

- Select "Function Mode" by navigating with the arrow key.
- Press the Enter button to confirm.
- Select "Auto Program" by navigating with the arrow key.
- Press the Enter button to confirm.
- Select "Master" or "Alone". The selection "Alone" means Stand Alone-mode and "Master" that the device is defined as master.
- Press the Enter button to confirm.
- Press the MODE/ESC button in order to return to the main menu.

#### **3. Program selection for Auto Pro Part**

- Select "Edit program" by navigating with the arrow key.
- Press the Enter button to confirm.
- Select "Select programs" by navigating with the arrow key.
- Press the Enter button to confirm.
- Select "Auto Pro Part 1", "Auto Pro Part 2" or "Auto Pro Part 3", and then select which Slave program is to be sent. Selection "Part 1" means, that the Slave unit runs the same program as the master units.
- Press the Enter button to confirm.
- Press the MODE/ESC button in order to return to the main menu.

#### **4. Program selection for Edit Program**

- Select "Edit program" by navigating with the arrow key.
- Press the Enter button to confirm.
- Select "Edit program" by navigating with the arrow key.
- Press the Enter button to confirm.
- Select the desired program. With this function you can edit specific scenes into a specific program.
- Press the Enter button to confirm.
- Press the MODE/ESC button in order to return to the main menu.

### 5. Automatic Scene Recording

- Select "Edit program" by navigating with the arrow key.
- Press the Enter button to confirm.
- Select "Edit scenes" by navigating with the arrow key.
- Select the desired scene numbers. You can program a maximum number of 250
- Press the Enter button to confirm.
- Press the MODE/ESC button in order to return to the main menu.

#### Example:

Program 2 includes scenes: 10, 11, 12, 13

Program 4 includes scenes: 8, 9, 10

Program 6 includes scenes: 12, 13, 14, 15

Auto Pro Part 1 is Program 2;

Auto Pro Part 2 is Program 3;

Auto Pro Part 3 is Program 6

The 3 Slave groups run the Auto Program in certain time segments, as shown in the following picture:

#### Part 1:

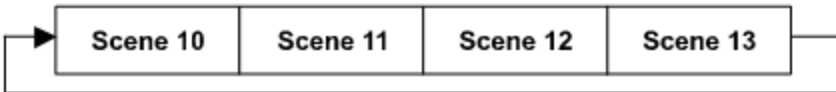

#### Part 2:

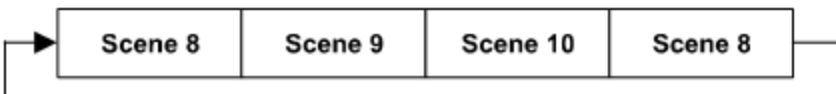

#### Part 3:

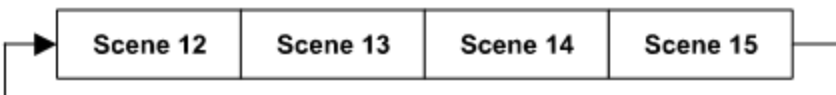

# Preset Programming and Playback

SolaSpot 2000 fixtures can be programmed through the on board menu system using Preset Programming. This section describes how to program your fixtures for stand-alone operation using the on-board memory in each fixture to create and store scenes.

## Preset Programming Overview

Presets are built from combining scenes into programs and then assigning the programs to Program Partitions for playback by a fixture designated as the Master and, if desired, groups of slave fixtures assigned to a Program Partition. SolaSpot 2000 fixtures ship with factory programmed scenes and programs ready for you to use or edit.

### Creating presets consists of performing the following steps:

- Designating a fixture as the Master
- Selecting/Editing Scenes
- Sequencing Scenes into Programs
- Sequencing Programs into Program Partitions
- Configuring slave fixtures on the link to playback a Program Partition from the master

### Navigating to the Preset Menu

To enter the Preset Menu:

- Press the **[MODE/ESC]** button to enter the first level of the menu system. The display will show Address and Info as the first two options in the top menu level.
- *The red star [\*] indicates the current menu.*
- Using the **[UP],[DOWN]** buttons, scroll to **Preset**.
- Press the **[Enter]** button to select.

### Master and Slave

The following example shows the relationship between scenes, programs and partitions programmed on the Master and how slave groups are assigned.

- Groups of scenes are edited into Programs 1–6 on the fixture designated as Master
- Program 2 is assigned to Part 1
- Program 4 is assigned to Part 2
- Program 6 is assigned to Part 3
- Fixtures assigned as Slave 1 playback Part 1
- Fixtures assigned as Slave 2 playback Part 2
- Fixtures assigned as Slave 3 playback Part 3
- Scene 4 Scene 5 Scene 6 Scene 7



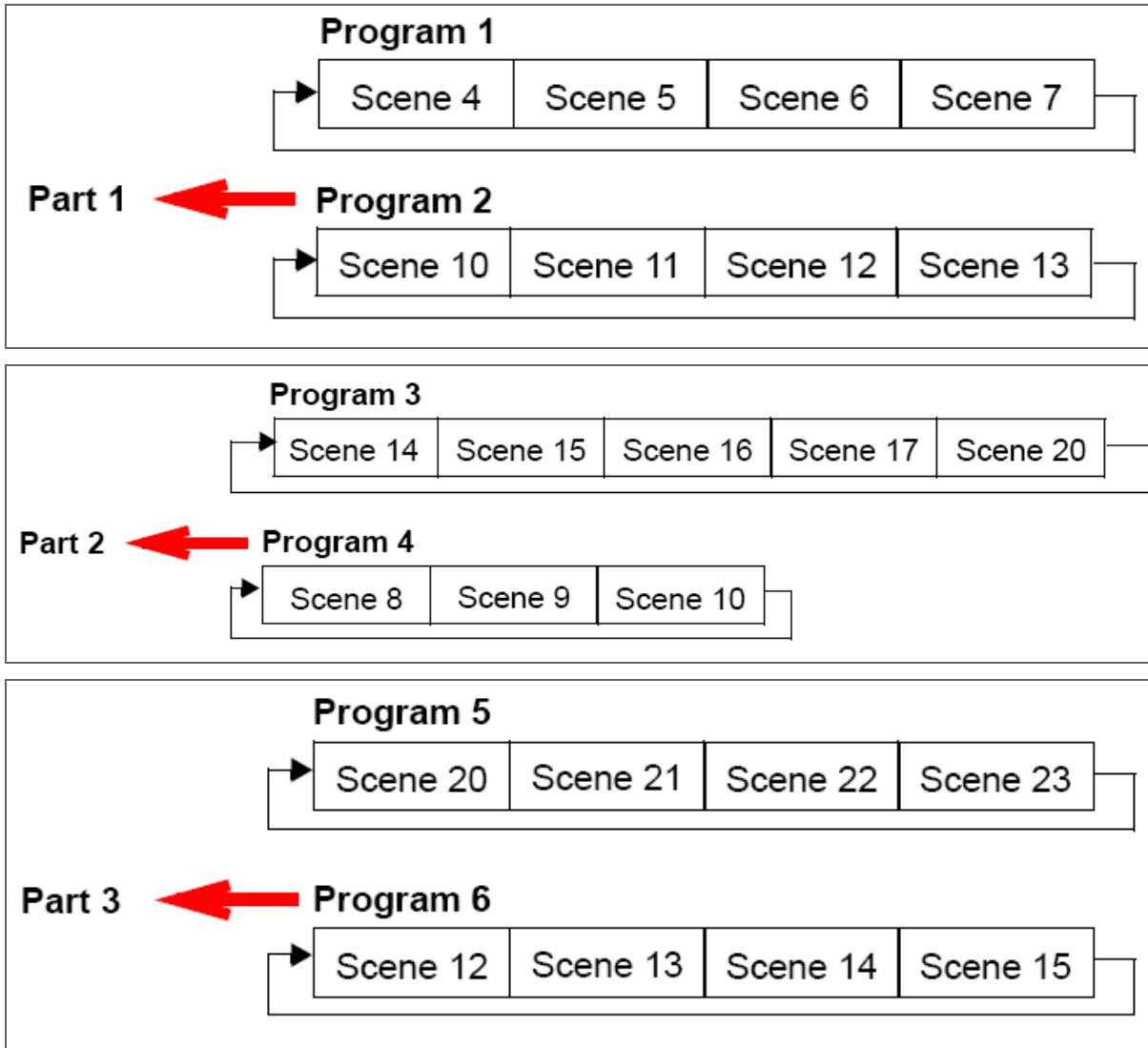

## Preset Menu

### Playback Settings

Preset programming requires one fixture to act as the Master. All other SolaSpot fixtures on the link can then be set as slaves to playback the Master presets. Slave fixtures receive all their preset parameter and timing information from the master fixture. Playback settings designate a fixture as a master or a slave and also allow you to revert from Auto Programming to DMX control from console or set a fixture in Master or standalone mode for audio control.

### Automatic Program Run

This Playback option lets you designate a fixture to playback in Standalone mode or as a Master. **Alone** is the default setting.

To designate a fixture as a Master:

- Navigate to and select the Preset menu.
- Use the[UP],[DOWN] buttons to scroll to Playback menu and press [Enter]to select.

- Use the **[UP],[DOWN]** buttons to scroll to Auto Program menu and press **[Enter]** to select.
- Use the **[UP],[DOWN]** buttons to scroll to Master and press **[Enter]** to select. Your choice will be shown in the display.

### Set to Slave

After a preset program is defined on a Master fixture, other SolaSpot 2000 fixtures on the same DMX link can be designated slaves to playback Program Part 1, 2 or 3 as defined on the Master fixture.

To designate a fixture as a Slave:

- Navigate to and select the Preset menu.
- Use the **[UP],[DOWN]** buttons to scroll to **Playback** menu and press **[Enter]** to select.
- Use the **[UP],[DOWN]** buttons to scroll to **Set To Slave** menu and press **[Enter]** to select.
- Use the **[UP],[DOWN]** buttons to scroll to **Slave1, Slave2, or Slave3** option and press **[Enter]** to select.
- Your choice will be shown in the display.

### DMX Control

Selecting this option reverts the function from **Auto Program** (Preset Programming) to **DMX Receive** (console control). Selecting this option will take you back to the menu startup screen where **DMX Receive** will be displayed as the currently selected function.

### Music Control

This Playback option lets you designate a fixture to playback scenes based on audio triggers detected by the internal microphone in stand alone or as a Master. **Alone** is the default setting.

### Edit Scenes

A parameter is a fixture attribute that can be controlled to modify the light beam in terms of color, beam quality and pattern, intensity, or focus (position). DMX programming assigns a DMX value to each of the fixture's parameters. A scene is one combination of parameter settings.

SolaSpot fixtures provide 250 pre-programmed scenes you can use or edit to build a preset program. The first 64 scenes are factory created settings which can be edited as desired.

### Edit Scene Parameters

The **Edit Scenes** option lets you select a DMX value for any of the 35 parameters in the SolaSpot DMX protocol.

#### To edit the DMX parameters in a scene:

- Navigate to and select the **Preset** menu as shown on page 35.
- Use the **[UP],[DOWN]** buttons to scroll to the Edit Scenes option and press **[Enter]** to select.
- Use the **[UP],[DOWN]** buttons to scroll to the Scene number you wish to build on from 1-250 and press to **[Enter]** select.
- Use the **[UP],[DOWN]** buttons to scroll to the parameter you wish to edit (Pan, Tilt, MSpeed, Color Wheel, etc.) and press to **[Enter]** select.

Use the **[UP],[DOWN]** buttons to scroll to a new DMX value for the parameter you have selected and press **[Enter]** to select. This takes you back to parameter options. Continue through all parameters until your desired look is complete.

- When you are finished selecting all parameter values for a particular Scene, press the **[MODE/ESC]** button to return to the Preset level menu.

### **Edit Scene Time**

This Scene Edit option lets you set the scene time in seconds from 00.2s–99.9s. The default value is 00.3s. This value determines how long the scene will play before the next scene is triggered.

### **Set Fade Time**

This Scene Edit option lets you set a fade time value from 000–255. This value determines the crossfade time applied to parameters once the scene is triggered.

### **Set Input by Out**

This Scene Edit option allows you to capture the parameter values for a scene from DMX input into the fixture. Once you create a look from a DMX console do the following:

- Navigate to and select the Preset menu as shown on page 35.
- Use the **[UP],[DOWN]** buttons to scroll to the Edit Scenes option and press **[Enter]** to select.
- Use the **[UP],[DOWN]** buttons to scroll to the Scene number you wish to build on from 1-250 and press to **[Enter]** select.
- Use the **[UP],[DOWN]** button to scroll to the Input by Out and **[Enter]** press to select.
- The scene will record the current parameter values being input via DMX.
- When you are finished capturing DMX into a scene, press **[Enter]** to return to the main menu.

### **Edit Program**

This preset menu option lets you select from 10 factory set programs to edit. You can set up to 64 Scenes in a sequence of Steps for each program. You can also test the program at any time by selecting Program Test to playback the program as it is currently defined.

To edit a program:

- Navigate to and select the Preset menu.
- Use the **[UP],[DOWN]** buttons to scroll to Edit Prog. menu and press **[Enter]** to select.
- Use the **[UP],[DOWN]** buttons to scroll to a program from Program 1–Program 10 and press **[Enter]** to select.
- Use the **[UP],[DOWN]** buttons to scroll to the Step in the program you want to edit from Step 1 to Step 64 and press **[Enter]** to select. The display will show which scene is currently assigned to that step.
- Use the **[UP],[DOWN]** buttons to scroll to the scene you want to assign to the step and press **[Enter]** to select.
- When you have assigned all the steps you want, select End and press **[Enter]** to save the program.

### **Select Program**

This preset option lets you assign a Preset Program to one of three Program Partitions. A fixture assigned as a Slave can playback any Program Partition defined by the Master fixture.

#### ***Note: The Master fixture can only playback Program Partition 1***

To assign a program to each Program Partition:

- Navigate to and select the Preset menu as shown on page 35.
- Use the **[UP],[DOWN]** buttons to scroll to **Select Prog** menu and press **[Enter]** to select. Each Program Part, has 10 preset programs.
- Use the **[UP],[DOWN]** buttons to scroll to **Prog. Part 1** and press **[Enter]** to select.
- Use the **[UP],[DOWN]** buttons to scroll to a program from **Program 1–Program 10** and press **[Enter]** to select the program you want to include in the Program Part.

- Use the **[UP],[DOWN]** buttons to scroll to **Prog. Part 2** and press **[Enter]** to select.
- Use the **[UP],[DOWN]** buttons to scroll to a program from **Program 1–Program 10** and press **[Enter]** to select the program you want to include in the Program Part.
- Use the **[UP],[DOWN]** buttons to scroll to **Prog. Part 3** and press **[Enter]** to select.
- Use the **[UP],[DOWN]** buttons to scroll to a program from **Program 1–Program 10** and press **[Enter]** to select the program you want to include in the Program Part.
- Press the **[Mode / ESC]** button to return to the main menu.

### Scenes Input

This function allows you to capture multiple scenes from DMX values input to the fixture. You first define the number of scenes to capture and then each time a DMX value changes, a different scene will be captured.

1. Navigate to and select the Preset menu.
2. Use the buttons to scroll to the Scenes Input option and press to select.
3. Use the buttons to set the starting scene number.
4. Use the buttons to set the ending scene number. With each change of any DMX value, the capturing scene will advance to the next one in the range.
5. When all scenes have been recorded, the scenes input menu will automatically exit.

Note: During Scenes Input recording, the SolaSpot 2000 does not playback the DMX input, it only captures it. You must edit or playback the scenes after recording to see the results. It is best to prepare the scenes on a DMX controller with a zero crossfade for all parameters between each step. Remember any change of a DMX value will advance to the next scene to capture.

# DMX Control Protocol

The most current DMX Control Protocol data for the SolaSpot 2000 can be found on the High End Systems, Inc. website

<https://www.highend.com/SolaSpot2000-DMXProtocol>.

The following data is current as of protocol version 1.1, revision date July 13, 2017.

Standard Protocol	
Channel	Construct
1	Pan Coarse
2	Pan Fine
3	Tilt Coarse
4	Tilt Fine
5	Mix Color Function
6	Cyan
7	Magenta
8	Yellow
9	CTO
10	Static Color 1 Function
11	Static Color 1 Position
12	Gobo 1 Function
13	Gobo 1 Position
14	Gobo 1 Rotate Function
15	Gobo 1 Rotate Coarse
16	Gobo 1 Rotate Fine
17	Gobo 2 Function
18	Gobo 2 Position
19	Gobo 2 Rotate Function
20	Gobo 2 Rotate Coarse
21	Gobo 2 Rotate Fine
22	Animation 1 Function
23	Animation 2 Function
24	Prism 1 Function
25	Prism 2 Function
26	Prism 1&2 Rotate Coarse
27	Prism 1&2 Rotate Fine
28	Frost
29	Focus Coarse
30	Focus Fine
31	Zoom Coarse
32	Zoom Fine
33	Auto Focus
34	Auto Focus Fine
35	Iris
36	Shutter/LED Function
37	Shutter/LED
38	Dim Coarse
39	Dim Fine
40	Mspeed
41	Control
42	Indigo Highlighter Function
43	Indigo Highlighter Dim

Channel	Marketing Construct	Description	Decimal Low	Decimal High	Percent Low	Percent High	Hex Low	Hex High	Controller Defaults	
1	Pan	Pan Coarse	0	255	0%	100%	00h	FFh	127	
2	Pan	Pan Fine	0	255	0%	100%	00h	FFh	255	
3	Tilt	Tilt Coarse	0	255	0%	100%	00h	FFh	127	
4	Tilt	Tilt Fine	0	255	0%	100%	00h	FFh	255	
5	Color Mix Function	Pure Mix	0	31	0%	12%	00h	1Fh	0	
		Cycle	32	47	13%	18%	20h	2Fh		
		Random	48	63	19%	25%	30h	3Fh		
		Reserved	64	255	25%	100%	40h	FFh		
6 7 8	Cyan Magenta Yellow	Pure Mix							255	
		Full Saturation	0		100%		00h			
		Open	255		0%		FFh			
		Cycle & Random Modes. Scan Speed controlled by Cyan Channel								
		Slow Rate	0		0%		00h			
		Fast Rate	255		100%		FFh			
		Continuous mode (NOTE 1)								
Positioning from 0-360 degrees			0	255	0%	100%	00h	FFh		
9	CTO	Full Saturation	0		0%		00h		255	
		Open (White)	255		100%		FFh			
10	Static Color 1 Function	Full Speed Control								
		Indexed	0	15	0%	6%	00h	0Fh	48	
		Forward Spin	16	31	6%	12%	10h	1Fh		
		Reverse Spin	32	47	13%	18%	20h	2Fh		
		Continuous	48	63	19%	25%	30h	3Fh		
		Fast Scan	64	79	25%	31%	40h	4Fh		
		Random	80	95	31%	37%	50h	5Fh		
		Reserved	96	255	38%	100%	60h	FFh		
Reserved										
11	Static Color 1 Position	Indexed, Scan & Blink modes								
		1. Open (White)	0	16	0%	6%	00h	10h	0	
		2. (Open/Red)	17	32	7%	13%	11h	20h		
		3. (Red)	33	48	13%	19%	21h	30h		
		4. (Red/Blue)	49	64	19%	25%	31h	40h		
		5. (Blue)	65	80	25%	31%	41h	50h		
		6. (Blue/Green)	81	96	32%	38%	51h	60h		
		7. (Green)	97	112	38%	44%	61h	70h		
		8. (Green/Orange)	113	128	44%	50%	71h	80h		
		9. (Orange)	129	144	51%	56%	81h	90h		
		10. (Orange/Magenta)	145	160	57%	63%	91h	A0h		
		11. (Magenta)	161	176	63%	69%	A1h	B0h		
		12. (Magenta/Dark Blue)	177	192	69%	75%	B1h	C0h		
		13. (Dark Blue)	193	208	76%	82%	C1h	D0h		
		14. (Dark Blue/Open)	209	224	82%	88%	D1h	E0h		
1. Open (White)	225	255	88%	100%	E1h	FFh				
Spin & Random modes										
Stop	0		0%	0%	00h	00h				
Slowest to fastest	255		100%	0%	FFh	00h				
Continuous mode										
Positioning from 0-360 degrees			0	255	0%	100%	00h	FFh		
12	Gobo 1 Function	Full Speed Control								
		Indexed	0	15	0%	6%	00h	0Fh	0	
		Forward Wheel Spin	16	31	6%	12%	10h	1Fh		
		Reverse Wheel Spin	32	47	13%	18%	20h	2Fh		
		Scan	48	63	19%	25%	30h	3Fh		
		Random	64	79	25%	31%	40h	4Fh		
		TBD/Indexed	80	255	31%	100%	50h	FFh		

13	Gobo 1 Position	Indexed, Scan & Blink modes							0
		1. (Open)	0	31	0%	12%	00h	1Fh	
		2. (Seashell)	32	63	13%	25%	20h	3Fh	
		3. (Crescent)	64	95	25%	37%	40h	5Fh	
		4. (Abstract)	96	127	38%	50%	60h	7Fh	
		5. (Fracture)	128	159	50%	62%	80h	9Fh	
		6. (Zebra)	160	191	63%	75%	A0h	BFh	
		7. (Shower)	192	223	75%	87%	C0h	DFh	
		1. (Open)	224	255	88%	100%	E0h	FFh	
		Spin & Random modes							
Rotate Stop	0	3	0%	1%	00h	03h			
Slowest to fastest	4	255	2%	100%	04h	FFh			
14	Gobo 1 Rotate Function	Full Speed Control							0
		Indexed	0	15	0%	6%	00h	0Fh	
		Forward Rotate	16	31	6%	12%	10h	1Fh	
		Reverse Rotate	32	47	13%	18%	20h	2Fh	
		Forward Strobe Rotate (Gobo animate)	48	63	19%	25%	30h	3Fh	
		Reverse Strobe Rotate (Gobo animate)	64	79	25%	31%	40h	4Fh	
		Reserved	80	255	31%	100%	50h	FFh	
15	Gobo 1 Rotate Coarse	Indexed/Blink Modes							127
		Position 0-360 degrees	0	255	0%	100%	00h	FFh	
		Forward/Reverse/Forward Strobe/Reverse Strobe Rotate Modes							
		Rotate Stop	0	3	0%	1%	00h	03h	
16	Gobo 1 Rotate Fine	Indexed Mode							255
		Low Order Byte 0-360 degrees	0	255	0%	100%	00h	FFh	
17	Gobo 2 Function	Full Speed Control							0
		Indexed	0	15	0%	6%	00h	0Fh	
		Forward Wheel Spin	16	31	6%	12%	10h	1Fh	
		Reverse Wheel Spin	32	47	13%	18%	20h	2Fh	
		Scan	48	63	19%	25%	30h	3Fh	
		Random	64	79	25%	31%	40h	4Fh	
		TBD/Indexed	80	255	31%	100%	50h	FFh	
18	Gobo 2 Position	Indexed, Scan & Blink modes							0
		1. (Open)	0	31	0%	12%	00h	1Fh	
		2. (Strikes)	32	63	13%	25%	20h	3Fh	
		3. (Triangles)	64	95	25%	37%	40h	5Fh	
		4. (Woven)	96	127	38%	50%	60h	7Fh	
		5. (Dense Foliage)	128	159	50%	62%	80h	9Fh	
		6. (Ice)	160	191	63%	75%	A0h	BFh	
		7. (Tunnel)	192	223	75%	87%	C0h	DFh	
		1. (Open)	224	255	88%	100%	E0h	FFh	
		Spin & Random modes							
Rotate Stop	0	3	0%	1%	00h	03h			
Slowest to fastest	4	255	2%	100%	04h	FFh			
19	Gobo 2 Rotate Function	Full Speed Control							0
		Indexed	0	15	0%	6%	00h	0Fh	
		Forward Rotate	16	31	6%	12%	10h	1Fh	
		Reverse Rotate	32	47	13%	18%	20h	2Fh	
		Forward Strobe Rotate (Gobo animate)	48	63	19%	25%	30h	3Fh	
		Reverse Strobe Rotate (Gobo animate)	64	79	25%	31%	40h	4Fh	
		Reserved	80	255	31%	100%	50h	FFh	
20	Gobo 2 Rotate Coarse	Indexed/Blink Modes							127
		Position 0-360 degrees	0	255	0%	100%	00h	FFh	
		Forward/Reverse/Forward Strobe/Reverse Strobe Rotate Modes							
		Rotate Stop	0	3	0%	1%	00h	03h	
21	Gobo 2 Rotate Fine	Indexed Mode							255
		Low Order Byte 0-360 degrees	0	255	0%	100%	00h	FFh	

22	Animation 1 Function	Disengaged	0	3	0%	1%	00h	03h	0	
		Engaged, static	4	6	2%	2%	04h	06h		
		Engaged, motion stopped	7	8	3%	3%	07h	08h		
		Engaged, Forward Spin speed slow to fast	9	70	4%	27%	09h	46h		
		Engaged, Reverse Spin speed slow to fast	71	131	28%	51%	47h	83h		
		Engaged, Forward Strobe rotate slow to fast	132	193	52%	76%	84h	C1h		
23	Animation 2 Function	Disengaged	0	3	0%	1%	00h	03h	0	
		Engaged, static	4	6	2%	2%	04h	06h		
		Engaged, motion stopped	7	8	3%	3%	07h	08h		
		Engaged, Forward Spin speed slow to fast	9	70	4%	27%	09h	46h		
		Engaged, Reverse Spin speed slow to fast	71	131	28%	51%	47h	83h		
		Engaged, Forward Strobe rotate slow to fast	132	193	52%	76%	84h	C1h		
24	Prism 1 Function	Full Speed Control								0
		Disengaged	0	15	0%	6%	00h	0Fh		
		Continuous	16	31	6%	12%	10h	1Fh		
		Forward Spin	32	47	13%	18%	20h	2Fh		
		Reverse Spin	48	63	19%	25%	30h	3Fh		
		Forward Strobe Rotate (Effect animate)	64	79	25%	31%	40h	4Fh		
		Reverse Strobe Rotate (Effect animate)	80	95	31%	37%	50h	5Fh		
		Reserved	96	255	38%	100%	60h	FFh		
25	Prism 2 Function	Full Speed Control								0
		Disengaged	0	15	0%	6%	00h	0Fh		
		Continuous	16	31	6%	12%	10h	1Fh		
		Forward Spin	32	47	13%	18%	20h	2Fh		
		Reverse Spin	48	63	19%	25%	30h	3Fh		
		Forward Strobe Rotate (Effect animate)	64	79	25%	31%	40h	4Fh		
		Reverse Strobe Rotate (Effect animate)	80	95	31%	37%	50h	5Fh		
		Reserved	96	255	38%	100%	60h	FFh		
26	Prism 1 & 2 Rotate Coarse	Continuous mode								127
		Position 0-360 degrees	0	255	0%	100%	00h	FFh		
		Forward/Reverse/Forward Strobe/Reverse Strobe Rotate Modes								
		Rotate Stop	0	3	0%	1%	00h	03h		
27	Prism 1 & 2 Rotate Fine	Rotate Slowest to Fastest	4	255	2%	100%	04h	FFh	255	
		Continuous mode								
28	Frost	Low Order Byte 0-360 degrees	0	255	0%	100%	00h	FFh	0	
		Open (hard edge)	0		0%	0%	00h	00h		
		Variable edge hard to soft)	1	127	0%	50%	01h	7Fh		
		Soft Edge	128	135	50%	53%	80h	87h		
		Periodic strobe	136	151	53%	59%	88h	97h		
		Random strobe	152	167	60%	65%	98h	A7h		
29	Focus Coarse	Open (hard edge)	168	225	66%	88%	A8h	E1h	127	
		Focus In	0		0%		00h			
30	Focus Fine	Focus Out	255		100%		FFh	255		
		Zoom In	0		0%		00h		127	
31	Zoom Coarse	Zoom Out	255		100%		FFh			
		32	Zoom Fine	Zoom In	0		0%		00h	255
Zoom Out	255				100%		FFh			
33	Auto Focus	Auto Focus Off	0	15	0%	6%	00h	0Fh	0	
		5m	16	31	6%	12%	10h	1Fh		
		7.5m	32	47	13%	18%	20h	2Fh		
		10m	48	255	19%	100%	30h	FFh		
34	Auto Focus Fine	Focus In Fine	0		0%		00h	0		
		Focus Out Fine	255		100%		FFh			
35	Iris	Iris Closed	0		0%		00h	255		
		Iris Open	255		100%		FFh			



36	Shutter/LED Functions	Normal Shutter Functions	0	31	0%	12%	00h	1Fh	0	
		Random Random strobe	32	63	13%	25%	20h	3Fh		
		Synchronous Random Strobe	64	95	25%	37%	40h	5Fh		
		Normal Shutter Functions	96	255	38%	100%	60h	FFh		
37	Shutter/LED	Normal/Random/Sync Random shutter functions.								
		Close	0	23	0%	9%	00h	17h	255	
		Strobe Rate (slow to fast)	24	229	9%	90%	18h	E5h		
		Open	230	255	90%	100%	E6h	FFh		
38	Dim Coarse	Close	0		0%		00h			0
		Open	255		100%		FFh			
39	Dim Fine		0		0%		00h		0	
			255		100%		FFh			
40	Mspeed	Disable	0	3	0%	1%	00h	03h	0	
		Longest (252.7 seconds)	4		2%		04h			
		Shortest (0.15 seconds)	255		100%		FFh			
41	Control	The Control channel should not be crossfaded. No shutter channel requirement.								
		Safe (normal operation )	0	9	0%	4%	00h	09h	0	
		Pan & Tilt Mspeed Off	10	19	4%	7%	0Ah	13h		
		Display Off (send 20 packets)	20	28	8%	11%	14h	1Ch		
		Display On (send 20 packets)	29	35	11%	14%	1Dh	23h		
		TBD	36	48	14%	19%	24h	30h		
		Home All (send 20 packets)	49	68	19%	27%	31h	44h		
		Shutdown (send 80 packets)	69	75	27%	29%	45h	4Bh		
		Fan Control Modes (NOTE 1)								
		Studio fan control mode (send 20 packets)	76	82	30%	32%	4Ch	52h		
		Continuous fan control mode (send 20 packets)	83	89	33%	35%	53h	59h		
		Standard fan control mode (send 20 packets)	90	96	35%	38%	5Ah	60h		
		Disable Pan/Tilt motors	97	103	38%	40%	61h	67h		
		TBD	104	130	41%	51%	68h	82h		
		Audio Sync	131	160	51%	63%	83h	A0h		
		Internal Prog 1 scene 1-8 EEPROM	161	171	63%	67%	A1h	ABh		
		Internal Prog 2 scene 9-16 EEPROM	172	182	67%	71%	ACh	B6h		
		Internal Prog 3 scene 17-24 EEPROM	183	193	72%	76%	B7h	C1h		
		Internal Prog 4 scene 25-32 EEPROM	194	204	76%	80%	C2h	CCh		
		Internal Prog 5 scene 33-40 EEPROM	205	215	80%	84%	CDh	D7h		
Internal Prog 6 scene 41-48 EEPROM	216	226	85%	89%	D8h	E2h				
Internal Prog 7 scene 49-56 EEPROM	227	237	89%	93%	E3h	EDh				
TBD	238	255	93%	100%	EEh	FFh				
42	Indigo Highlighter Function	Indigo Highlighter Dim Tracking Mode								
		Continuous	0	15	0%	6%	00h	0Fh	0	
		Periodic Strobe (slow to fast)	16	41	6%	16%	10h	29h		
		Random Strobe (slow to fast)	42	67	16%	26%	2Ah	43h		
		TBD	68	127	27%	50%	44h	7Fh		
		Indigo Highlighter Independent Dim Mode								
		Continuous	128	143	50%	56%	80h	8Fh		
		Periodic Strobe (slow to fast)	144	169	56%	66%	90h	A9h		
Random Strobe (slow to fast)	170	195	67%	76%	AAh	C3h				
TBD	196	255	77%	100%	C4h	FFh				
43	Indigo Highlighter Dim	Indigo Highslihter Off	0		0%		00h		0	
		Indigo Highlighter 100%	255		100%		FFh			

## Protocol Notes

1. Continuous mode should take quickest path from 255-0, and 0-255.
  - Continuous mode color wheel aperture centers

Color	Center of color DMX value
Open	0
Red	337
Blue	72
Green	110
Orange	144
Magenta	184
Dark Blue	219

2. Fan Control Mode settings do not remain after power off, please resend fan control modes after power cycle.
3. Fans are fixed at medium RPM. LED output is 100% Depending on ambient temperature and use, the LED may variably dim down to protect itself.
4. Studio mode. Fan is variable to half RPM. LED output is 75% As ambient temperature increases the fans can increase towards half RPM. Depending on ambient temperature and use, the LED may variably dim down to protect itself.
5. Normal mode. Fan is variable to full RPM. LED output is 100% At high ambient >45C and after the LED is at full power for some time the LED will start to variably dim down to protect the LED.
6. Led temperature controlled dimming can be difficult to see.

# Error Codes

When you turn on the fixture, it will complete a start-up procedure. The display may show "Err channel is XX" if there are problems with one or more channels. "XX" stands for channel 1, 2, 3, 4, 5, 6 - testing positioning sensors. For example, when the display shows "Err channel is Color wheel", it means there is an error in channel 13. If there are errors on channel 1, channel 3, channel 7 at the same time, you may see the error message "Err channel is Pan movement", "Err channel is Tilt movement", "Err channel is Dimmer" flash repeated for 2 times, and then the fixture will generate a second reset. If the fixture error message is retained after performing reset more than 2 times, only the channels which have errors will not work properly, others can work. Please contact support if detailed assistance is needed.

## **PAN- Er**

(PAN-yoke movement error) This message will appear after the reset of the fixture if the yoke's magnetic-indexing circuit malfunction (sensor failed or magnet missing) or the stepping-motor is defective (or its driving IC on the main PCB). The PAN- movement is not located in the default position after the reset.

## **TILT- Er**

(TILT-head movement error) This message will appear after the reset of the fixture if the head's magnetic-indexing circuit malfunctions (sensor failed or magnet missing) or the stepping-motor is defective (or its driving IC on the main PCB). The TILT- movement is not located in the default position after the reset.

## **Gobo Wheel 1 Er**

(Gobo Wheel 1- error) This message will appear after the reset of the fixture if the magnetic-indexing circuit malfunction (sensor failed or magnet missing) or the stepping-motor is defective (or its driving IC on the main PCB). The Gobo Wheel 1 is not located in the default position after the reset.

## **Gobo Rot. 1 Er**

(Gobo Rot. 1- error) This message will appear after the reset of the fixture if the magnetic-indexing circuit malfunction (sensor failed or magnet missing) or the stepping-motor is defective (or its driving IC on the main PCB). The Gobo Rot. 1 is not located in the default position after the reset.

## **Gobo Wheel 2 Er**

(Gobo Wheel 2- error) This message will appear after the reset of the fixture if the magnetic-indexing circuit malfunction (sensor failed or magnet missing) or the stepping-motor is defective (or its driving IC on the main PCB). The Gobo Wheel 2 is not located in the default position after the reset.

## **Focus Er**

(Focus - error) This message will appear after the reset of the fixture if the magnetic-indexing circuit malfunction (sensor failed or magnet missing) or the stepping-motor is defective (or its driving IC on the main PCB). The Focus is not located in the default position after the reset.

**Zoom Er**

(Zoom –wheel error) This message will appear after the reset of the fixture if the head's magnetic-indexing circuit malfunctions (sensor failed or magnet missing) or the stepping-motor is defective (or its driving IC on the main PCB). The Zoom - wheel is not located in the default position after the reset.

**Animation Er**

(Animation –wheel error) This message will appear after the reset of the fixture if the head's magnetic-indexing circuit malfunctions (sensor failed or magnet missing) or the stepping-motor is defective (or its driving IC on the main PCB). The Animation – wheel is not located in the default position after the reset.