

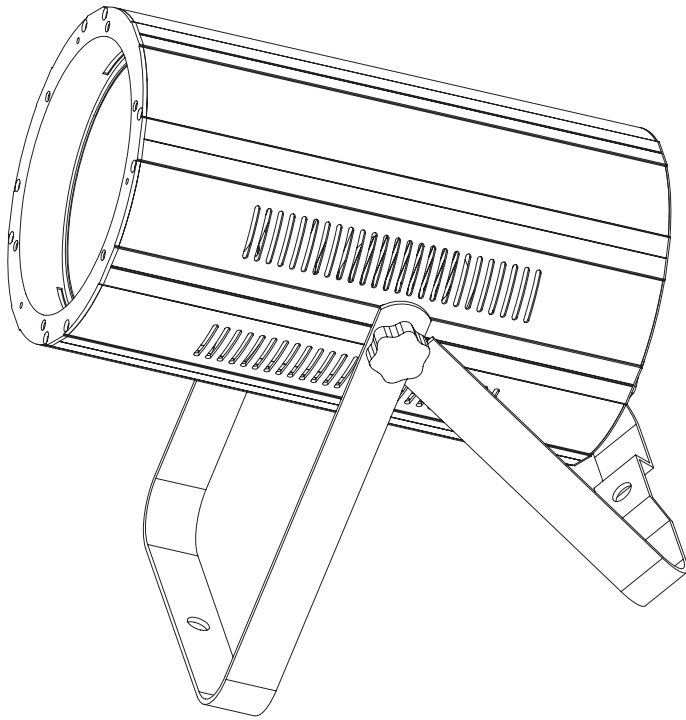

COB CANNON WASH



User Instructions



©2015 ADJ Products, LLC all rights reserved. Information, specifications, diagrams, images, and instructions herein are subject to change without notice. ADJ Products, LLC logo and identifying product names and numbers herein are trademarks of ADJ Products, LLC. Copyright protection claimed includes all forms and matters of copyrightable materials and information now allowed by statutory or judicial law or hereinafter granted. Product names used in this document may be trademarks or registered trademarks of their respective companies and are hereby acknowledged. All non-ADJ Products, LLC brands and product names are trademarks or registered trademarks of their respective companies.

ADJ Products, LLC and all affiliated companies hereby disclaim any and all liabilities for property, equipment, building, and electrical damages, injuries to any persons, and direct or indirect economic loss associated with the use or reliance of any information contained within this document, and/or as a result of the improper, unsafe, insufficient and negligent assembly, installation, rigging, and operation of this product.

Europe Energy Saving Notice
Energy Saving Matters (EuP 2009/125/EC)
Saving electric energy is a key to help protecting the environment. Please turn off all electrical products when they are not in use. To avoid power consumption in idle mode, disconnect all electrical equipment from power when not in use. Thank you!

COB Cannon Wash

Introduction

Unpacking: Thank you for purchasing the COB Cannon Wash by ADJ Products, LLC. Every COB Cannon Wash has been thoroughly tested and has been shipped in perfect operating condition. Carefully check the shipping carton for damage that may have occurred during shipping. If the carton appears to be damaged, carefully inspect your fixture for any damage and be sure all accessories necessary to operate the unit has arrived intact. In the case damage has been found or parts are missing, please contact our toll free customer support number for further instructions. Do not return this unit to your dealer without first contacting customer support.

Introduction: The ADJ COB Cannon Wash is a DMX intelligent, high powered LED wash fixture. This wash has five operating modes: Sound Active mode, Auto mode, RGBA Dimmer mode, Static Color mode, and DMX control mode. This fixture can be used in a stand alone mode or connected in a Master/Slave configuration. To optimize the performance of this product, please read these operating instructions carefully to familiarize yourself with the basic operations of this unit. These instructions contain important safety information regarding the use and maintenance of this unit. Please keep this manual with the unit, for future reference.

Customer Support: ADJ Products, LLC provides a customer support line, to provide set up help and to answer any question should you encounter problems during your set up or initial operation. You may also visit us on the web at www.adj.com for any comments or suggestions. Service Hours are Monday through Friday 8:00 a.m. to 4:30 p.m. Pacific Standard Time.

Voice: (323) 582-3322

Fax: (323) 582-3108

E-mail: support@AmericanDJ.com

Warning! To prevent or reduce the risk of electrical shock or fire, do not expose this unit to rain or moisture.

Caution! There are no user serviceable parts inside this unit. Do not attempt any repairs yourself, doing so will void your manufactures warranty. In the unlikely event your unit may require service please contact ADJ Products, LLC.

PLEASE recycle the shipping carton when ever possible.

COB Cannon Wash

Features

- Five Operating Modes
- Electronic Dimming 0-100%
- 5 Selectable Dimming Curves
- 64 Color Macros
- Built in Microphone
- Optional 40° & 50° Lenses Included
- DMX-512 protocol
- 3-Pin & 5-Pin DMX Connections
- 7 DMX Modes: 3 Channel Mode, 4 Channel Mode, 5 Channel Mode, 6 Channel Mode, 7 Channel Mode, 9 Channel Mode, & 10 Channel Mode.
- ADJ RFC compatible (Not Included)
- Power Cord Daisy Chain (See page 26)

COB Cannon Wash

Warranty Registration

The COB Cannon Wash carries a 2 year limited warranty. Please fill out the enclosed warranty card to validate your purchase. All returned service items whether under warranty or not, must be freight pre-paid and accompany a return authorization (R.A.) number. The R.A. number must be clearly written on the outside of the return package. A brief description of the problem as well as the R.A. number must also be written down on a piece of paper included in the shipping carton. If the unit is under warranty, you must provide a copy of your proof of purchase invoice. You may obtain a R.A. number by contacting our customer support team on our customer support number. All packages returned to the service department not displaying a R.A. number on the outside of the package will be returned to the shipper.

COB Cannon Wash

Installation

The unit should be mounted using a mounting clamp (not provided), affixing it to the mounting bracket that is provided with the unit. Always ensure that the unit is firmly fixed to avoid vibration and slipping while operating. Always ensure that the structure to which you are attaching the unit is secure and is able to support a weight of 10 times the unit's weight. Also, always use a safety cable that can hold 12 times the weight of the unit when installing the fixture. The equipment must be installed by a professional, and it must be installed in a place where it is out of the reach of people's grasp.

COB Cannon Wash

Safety Precautions

- To reduce the risk of electrical shock or fire, do not expose this unit rain or moisture
- Do not spill water or other liquids into or on to your unit.
- Do not attempt to operate this unit if the power cord has been frayed or broken. Do not attempt to remove or break off the ground prong from the electrical cord. This prong is used to reduce the risk of electrical shock and fire in case of an internal short.
- Disconnect from main power before making any type of connection.
- Do not remove the cover under any conditions. There are no user serviceable parts inside.
- Never operate this unit when it's cover is removed.
- Never plug this unit in to a dimmer pack
- Always be sure to mount this unit in an area that will allow proper ventilation. Allow about 6" (15cm) between this device and a wall.
- Do not attempt to operate this unit, if it becomes damaged.
- This unit is intended for indoor use only, use of this product out doors voids all warranties.
- During long periods of non-use, disconnect the unit's main power.
- Always mount this unit in safe and stable matter.
- Power-supply cords should be routed so that they are not likely to be walked on or pinched by items placed upon or against them, paying particular attention to the point they exit from the unit.
- Cleaning -The fixture should be cleaned only as recommended by the manufacturer. See page 26 for cleaning details.
- Heat -The appliance should be situated away from heat sources such as radiators, heat registers, stoves, or other appliances (including amplifiers) that produce heat.
- The fixture should be serviced by qualified service personnel when:
 - A. The power-supply cord or the plug has been damaged.
 - B. Objects have fallen, or liquid has been spilled into the appliance.
 - C. The appliance has been exposed to rain or water.
 - D. The appliance does not appear to operate normally or exhibits a marked change in performance.

COB Cannon Wash

DMX Set Up

Power Supply: The ADJ COB Cannon Wash contains a automatic voltage switch, which will auto sense the voltage when it is plugged into the power source. With this switch there is no need to worry about the correct power voltage, this unit can be plugged in anywhere.

DMX-512: DMX is short for Digital Multiplex. This is a universal protocol used as a form of communication between intelligent fixtures and controllers. A DMX controller sends DMX data instructions from the controller to the fixture. DMX data is sent as serial data that travels from fixture to fixture via the DATA "IN" and DATA "OUT" XLR terminals located on all DMX fixtures (most controllers only have a DATA "OUT" terminal).

DMX Linking: DMX is a language allowing all makes and models of different manufactures to be linked together and operate from a single controller, as long as all fixtures and the controller are DMX compliant. To ensure proper DMX data transmission, when using several DMX fixtures try to use the shortest cable path possible. The order in which fixtures are connected in a DMX line does not influence the DMX addressing. For example; a fixture assigned a DMX address of 1 may be placed anywhere in a DMX line, at the beginning, at the end, or anywhere in the middle. When a fixture is assigned a DMX address of 1, the DMX controller knows to send DATA assigned to address 1 to that unit, no matter where it is located in the DMX chain.

Data Cable (DMX Cable) Requirements (For DMX Operation):

The COB Cannon Wash can be controlled via DMX-512 protocol. The COB Cannon Wash has 7 DMX modes, please see pages 9-10 for the different modes. The DMX address is set on the back panel of the COB Cannon Wash. Your unit and your DMX controller require a standard 3-pin or 5-pin XLR connector for data input and data output (Figure 1). We recommend Accu-Cable DMX cables. If you are making your own cables, be sure to use standard 110-120 Ohm shielded cable (This cable may be purchased at almost all pro lighting stores). Your cables should be made with a male and female XLR connector on either end of the cable. Also remember that DMX cable must be daisy chained and cannot be split.



Figure 1

Notice: Be sure to follow figures two and three when making your own cables. Do not use the ground lug on the XLR connector. Do not connect the cable's shield conductor to the ground lug or allow the shield conductor to come in contact with the XLR's outer casing. Grounding the shield could cause a short circuit and erratic behavior.



Figure 2

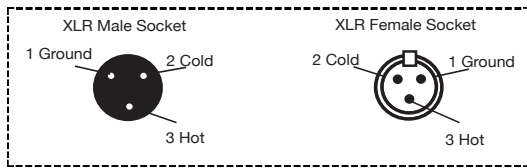

Figure 3

XLR Pin Configuration	
Pin 1 =	Ground
Pin 2 =	Data Compliment (negative)
Pin 3 =	Data True (positive)

Special Note: Line Termination. When longer runs of cable are used, you may need to use a terminator on the last unit to avoid erratic behavior. A terminator is a 110-120 ohm 1/4 watt resistor which is connected between pins 2 and 3 of a male XLR connector (DATA + and DATA -). This unit is inserted in the female XLR connector of the last unit in your daisy chain to terminate the line. Using a cable terminator (ADJ part number Z-DMX/T) will decrease the possibilities of erratic behavior.



Termination reduces signal errors and avoids signal transmission problems and interference. It is always advisable to connect a DMX terminal, (Resistance 120 Ohm 1/4 W) between PIN 2 (DMX-) and PIN 3 (DMX +) of the last fixture.

Figure 4

5-Pin XLR DMX Connectors. Some manufactures use 5-pin DMX-512 data cables for DATA transmission in place of 3-pin. 5-pin DMX fixtures may be implemented in a 3-pin DMX line. When inserting standard 5-pin data cables in to a 3-pin line a cable adaptor must be used, these adaptors are readily available at most electric stores. The chart below details a proper cable conversion.

3-Pin XLR to 5-Pin XLR Conversion		
Conductor	3-Pin XLR Female (Out)	5-Pin XLR Male (In)
Ground/Shield	Pin 1	Pin 1
Data Compliment (- signal)	Pin 2	Pin 2
Data True (+ signal)	Pin 3	Pin 3
Not Used		Do Not Use
Not Used		Do Not Use

System Menu: The display will lock after 30 seconds, press the MODE button for 3 seconds to unlock.

LED Display On/Off:

To set the LED display to turn off after 10 seconds, press the MODE button until “don” is displayed, press the UP button to display “doff”. Now the display will disappear after 10s. Press any button to turn the display on again. Be advised though that the display will turn off automatically after 10 seconds.

To set the display press the MODE button until “dXX” is displayed. Use the UP or DOWN buttons to select either:
 “don” = LED display on at all times.
 “doFF” = LED display shuts off after 10 seconds.

LED Display Inversion:

Follow these instructions to flip the display 180° so that the display can be read upside down.

1. Plug the fixture in and press the MODE button until “dXX” is displayed. “XX” represents either “on” or “oFF”.
2. Press the SET UP button until “Std” is displayed.
3. Press the UP or DOWN buttons to reverse the display 180°.

Operating Modes:

The COB Cannon Wash has five operating modes:

- **RGBA Dimmer Mode** - Choose one of the four colors to remain static or adjust the intensity of each color to make your desired color.
- **Sound-Active mode** - The unit will react to sound, chasing through the built in programs. There are 16 sound active modes.
- **Auto Mode** - There are 3 Auto Modes to choose from.
- **Static Color Mode** - There are 64 colors to choose from.
- **DMX control mode** - This function will allow you to control each individual fixtures traits with a standard DMX 512 controller.

RGBA Dimmer Mode:

1. Plug the fixture in and press the MODE button until:
2. When “r.XXX” is displayed you are in Red dimming mode. Press the UP and DOWN buttons to adjust intensity.

3. When “G.XXX” is displayed you are in Green dimming mode. Press the UP and DOWN buttons to adjust intensity.
4. When “b.XXX” is displayed you are in Blue dimming mode. Press the UP and DOWN buttons to adjust intensity.
5. When “A.XXX” is displayed you are in Amber dimming mode. Press the UP and DOWN buttons to adjust intensity.
6. After you have adjusted the RGBA colors to make your desired color you can then activate strobing by pressing the SET UP button to enter the Flash (strobe) mode.
7. “FS.XX” will be displayed, this is Flash mode. The Flash can be adjusted between “FS.00” (flash off) to “FS.15” (fastest flash).

Sound Active Mode:

In this mode the COB Cannon Wash will react to sound, and chase through the different colors.

1. Plug the fixture in and press the MODE button until “SoXX” is displayed. “XX” represents the sound active mode (1-16) currently displayed.
2. The fixture will now change via sound.
3. Press the SET UP button to adjust the sound sensitivity. “SJ-X” should be displayed. Use the UP or DOWN buttons to adjust the sensitivity. “SJ-1” is the lowest sensitivity, “SJ-8” is the highest.

Auto Run Mode:

There are 3 types of Auto Run Modes to choose from; Color Fade, Color Change, and both modes running together. The running speed is adjustable in all 3 modes.

1. Plug the fixture in and press the MODE button until either “AFXX”, “AJXX”, or “A-JF” is displayed.
 - AFXX = Color Fade mode, there are 16 Color Fade modes to choose from. Use the UP or DOWN buttons to scroll through the different Auto Fade modes.
 - AJXX = Color Change mode, there are 16 Color Change modes to choose from. Use the UP or DOWN buttons to scroll through the different Auto Change modes.
 - A-JF = Both Color Fade and Color Change modes running.
2. After you have chosen your desired running mode press the SET UP button until “SP.XX” is displayed. When this is displayed you can adjust the running speed of your desired program. Use the

UP or DOWN button to adjust the speed between “SP.01” (slowest) and “SP.16” (fastest). Once you have set your desired running speed, press the SET UP button to return to your desired Auto Run Mode.

Static Color Mode:

1. Plug the fixture in and press the MODE button until “CLXX” is displayed.
2. There are 64 colors to choose from. Select your desired color by pressing the UP and DOWN buttons. After you have selected your desired color you can activate strobing by pressing the SET UP button to enter the Flash (strobe) mode.
3. “FS.XX” will be displayed, this is Flash mode. The Flash can be adjusted between “FS.00” (flash off) to “FS.15” (fastest flash).

DMX Mode:

Operating through a DMX controller gives the user the freedom to create their own programs tailored to their own individual needs. This function also allows you to use your fixtures as spot lights. The COB Cannon Wash has 7 DMX modes: 3 channel mode, 4 channel mode, 5 channel mode, 6 channel mode, 7 channel mode, 9 channel mode, and a 10 channel mode. See page’s 14-22 for each mode’s DMX traits.

1. This function will allow you to control each individual fixture’s traits with a standard DMX 512 controller.
2. To run your fixture in DMX mode press the MODE button until “d.XXX” is displayed. “XXX” represents the current displayed DMX address. Use the UP or DOWN buttons to select your desired DMX address, then press the SETUP button to select your DMX Channel mode.
3. Use the UP or DOWN buttons to scroll through the DMX Channel modes. The Channel modes are listed below:
 - To run the 3 Channel Mode, press the MODE button until “Ch03” is displayed. This is the 3 Channel DMX Mode.
 - To run the 4 Channel Mode, press the MODE button until “Ch04” is displayed. This is the 4 Channel DMX Mode.
 - To run the 5 Channel Mode, press the MODE button until “Ch05” is displayed. This is the 5 Channel DMX Mode.
 - To run the 6 Channel Mode, press the MODE button until “Ch06”

is displayed. This is the 6 Channel DMX Mode.

- To run the 7 Channel Mode, press the MODE button until “Ch07” is displayed. This is the 7 Channel DMX Mode.
 - To run the 9 Channel Mode, press the MODE button until “Ch09” is displayed. This is the 9 Channel DMX Mode.
 - To run the 10 Channel Mode, press the MODE button until “Ch10” is displayed. This is the 10 Channel DMX Mode.
4. Please see pages 14-22 for DMX values and traits.
 5. After you have chosen your desired DMX Channel mode plug in the fixture via the XLR connections to any standard DMX controller.

Default Running Mode:

This is a default running mode. When this mode is activated all modes will return to their default settings.

1. Plug the fixture in and press the MODE button until “dXX” is displayed. “XX” represents either “on” or “off”.
2. Press the SET UP button until “dEFA” is displayed.
3. Press the UP and DOWN buttons simultaneously. Press the MODE button to exit.

DMX State:

This mode can be used as a precaution mode, that in case the DMX signal is lost, the operating mode chosen in the setup is the running mode the fixture will go into when the DMX signal is lost. You can also set this as the operating mode you would like the unit to return to when power is applied.

1. Plug the fixture in and press the MODE button until “d.XXX” is displayed. “XXX” represents the current displayed DMX address.
2. Press the SET UP button so that “nodn” is displayed. Use the UP and DOWN buttons to scroll through the DMX states.
 - “bLAC” (Blackout) - If the DMX signal is lost or interrupted, the unit will automatically go into stand by mode.
 - “LAsT” (Last State) - If the DMX signal is lost or interrupted, the fixture will stay in the last DMX set up. If power is applied and this mode is set, the unit will automatically go into the last DMX set up.
 - “ProG” (Auto Run) - If the DMX signal is lost or interrupted,

the unit will automatically go into Auto Run mode.

3. Use the UP and DOWN buttons to find your desired DMX state and press SET UP to confirm and exit.

Dimmer Curve:

This is used to set the dimming curve used with DMX mode. See page 27 for the dimming curves chart.

1. Plug the fixture in and press the MODE button until “d.XXX” is displayed. “XXX” represents the current displayed DMX address.
2. Press the SET UP button until “dr-X” is displayed. “X” represents the displayed dimmer curve (0-4).
 - 0 - Standard
 - 1 - Stage
 - 2 - TV
 - 3 - Architectural
 - 4 - Theatre
3. Press the UP or DOWN buttons to scroll through and select your desired dimming curve.

ADJ RFC:

This function is used to activate and deactivate the ADJ RFC (Remote Control). When this function is activated you can control the fixture using the ADJ RFC. Please see the next page for ADJ RFC controls and functions.

1. Plug the fixture in and press the MODE button until “dXX” is displayed. “XX” represents either “on” or “off”.
2. Press the SET UP button until “rFXX” is displayed. “XX” represents either “on” or “of”.
3. Press the UP or DOWN buttons to either activate the remote function (On) or deactivate it (Off).

This function will allow you to link units together to run in a Master-Slave mode. In a Master-Slave set up one unit will act as the controlling unit and the others will react to the controlling units built-in programs. Any unit can act as a Master or as a Slave however, only one unit can be programmed to act as the “Master.”

Master-Slave Connections and Settings:

1. Daisy chain your units via the XLR connector on the rear of the unit. Use standard XLR data cables to link your units together. Remember that the Male XLR connector is the input and the Female XLR connector is the output. The first unit in the chain (master) will use the female XLR connector only. The last unit in the chain will use the male XLR connector only.
2. Set the “Master” unit to your desired mode of operation.
3. On the “Slave” units press the MODE button until “SLAu” is displayed. Each “Slave” unit must be set to the same setting.
4. Connect the first “Slave” unit to the “Master.” The “Slave” unit(s) should now start following the “Master” unit.

The **ADJ RFC** remote (sold separately) has many different functions and allows you to control your COB Cannon Wash from long distance. The **ADJ RFC** remote can control your system up to 150 ft. To use the RFC you must first activate the fixtures receiver, to activate the receiver please see the instructions on page 11.

BLACKOUT - Pressing this button will blackout the fixture. Press this button for more than 3 seconds to activate default mode. All modes will return to their default settings.

AUTO RUN - This button lets you cycle through color fade mode, color change mode, and auto run mode. Each press of the button will change to the next mode. Color fade mode and color change mode have 16 different programs. You can use the “+” and “-” buttons to cycle through the 16 programs. You can control the speeds of each mode by pressing the SPEED button and then using the “+” and “-” buttons to adjust the speed.

SELECTION PROGRAM - Press this button to activate Static Color mode. Use the “+” and “-” buttons to scroll through the 64 colors. Once you have found your desired color press the FLASH button to activate strobing. Use the “+” and “-” buttons adjust the strobe speed.

FLASH - This button will activate the flash (strobe) effect. You can control the flash speed by pressing the “+” and “-” buttons.

SPEED - Press this button and use the “+” & “-” buttons to adjust the speed of the color fade mode, color change mode, and auto run.

SOUND ACTIVE - This button activates sound active mode. Use the “+” & “-” buttons to scroll through the 16 sound active modes and find your desired mode. Press the SOUND ACTIVE button again to access sound sensitivity adjustment. Use the “+” & “-” buttons to adjust the sound sensitivity level.

R G B W/A - Press either one of these buttons and then press the “+” or “-” to adjust the brightness. Press the Flash button to activate strobing and use the “+” or “-” buttons to adjust the strobe speed.

“+” and “-” - These buttons are used to adjust the flash rate, auto run speed, color fade speed, color change speed, sound sensitivity, and output intensity. These buttons are also used to scroll through the static colors, color fade programs, color change programs, and sound active programs.

COB Cannon Wash		3 Channel Mode
Channel	Value	Function
1	0 - 255	COLOR MACROS See page 23 for the Color Macro Chart
2	0 - 31 32 - 63 64 - 95 96 - 127 128 - 159 160 - 191 192 - 223 224 - 255	SHUTTER/STROBE LED OFF LED ON STROBING SLOW - FAST LED ON STROBE PULSE SLOW - FAST LED ON RANDOM STROBE SLOW - FAST LED ON
3	0 - 255	MASTER DIMMER 0% - 100%

COB Cannon Wash		4 Channel Mode
Channel	Value	Function
1	0 - 255	RED 0% - 100%
2	0 - 255	GREEN 0% - 100%
3	0 - 255	BLUE 0% - 100%
4	0 - 255	AMBER 0% - 100%

COB Cannon Wash		5 Channel Mode
Channel	Value	Function
1	0 - 255	RED 0% - 100%
2	0 - 255	GREEN 0% - 100%
3	0 - 255	BLUE 0% - 100%
4	0 - 255	AMBER 0% - 100%
5	0 - 255	MASTER DIMMER 0% - 100%

COB Cannon Wash		6 Channel Mode
Channel	Value	Function
1	0 - 255	RED 0% - 100%
2	0 - 255	GREEN 0% - 100%
3	0 - 255	BLUE 0% - 100%
4	0 - 255	AMBER 0% - 100%
5	0 - 31 32 - 63 64 - 95 96 - 127 128 - 159 160 - 191 192 - 223 224 - 255	SHUTTER/STROBE LED OFF LED ON STROBING SLOW - FAST LED ON STROBE PULSE SLOW - FAST LED ON RANDOM STROBE SLOW - FAST LED ON
6	0 - 255	MASTER DIMMER 0% - 100%

COB Cannon Wash		7 Channel Mode
Channel	Value	Function
1	0 - 255	RED 0% - 100%
2	0 - 255	GREEN 0% - 100%
3	0 - 255	BLUE 0% - 100%
4	0 - 255	AMBER 0% - 100%
5	0 - 31 32 - 63 64 - 95 96 - 127 128 - 159 160 - 191 192 - 223 224 - 255	SHUTTER/STROBE LED OFF LED ON STROBING SLOW - FAST LED ON STROBE PULSE SLOW - FAST LED ON RANDOM STROBE SLOW - FAST LED ON
6	0 - 255	MASTER DIMMER 0% - 100%
7	0 - 20 21 - 40 41 - 60 61 - 80 81 - 100 101 - 255	DIMMER CURVES STANDARD STAGE TV ARCHITECTURAL THEATRE DEFAULT TO UNIT SETTING

COB Cannon Wash		9 Channel Mode
Channel	Value	Function
1	0 - 255	RED 0% - 100%
2	0 - 255	GREEN 0% - 100%
3	0 - 255	BLUE 0% - 100%
4	0 - 255	AMBER 0% - 100%
5	0 - 31 32 - 63 64 - 95 96 - 127 128 - 159 160 - 191 192 - 223 224 - 255	SHUTTER/STROBE LED OFF LED ON STROBING SLOW - FAST LED ON STROBE PULSE SLOW - FAST LED ON RANDOM STROBE SLOW - FAST LED ON
6	0 - 255	MASTER DIMMER 0% - 100%
7	0 - 51 52 - 102 103 - 153 154 - 204 205 - 255	PROGRAM SELECTION MODE DIMMING MODE COLOR MACRO MODE COLOR CHANGE MODE COLOR FADE MODE SOUND ACTIVE MODE
8	0 - 255 0 - 15 16 - 31 32 - 47	COLOR MACROS/PROGRAMS/ SOUND ACTIVITY COLOR MACRO MODE (See page 23 for the Color Macro Chart) COLOR CHANGE PROGRAMS COLOR CHANGE 1 COLOR CHANGE 2 COLOR CHANGE 3

COB Cannon Wash		9 Channel Mode
Channel	Value	Function
8		COLOR MACROS/PROGRAMS/ SOUND ACTIVITY
		COLOR CHANGE PROGRAMS
	48 - 63	COLOR CHANGE 4
	64 - 79	COLOR CHANGE 5
	80 - 95	COLOR CHANGE 6
	96 - 111	COLOR CHANGE 7
	112 - 127	COLOR CHANGE 8
	128 - 143	COLOR CHANGE 9
	144 - 159	COLOR CHANGE 10
	160 - 175	COLOR CHANGE 11
	176 - 191	COLOR CHANGE 12
	192 - 207	COLOR CHANGE 13
	208 - 223	COLOR CHANGE 14
	224 - 239	COLOR CHANGE 15
	240 - 255	COLOR CHANGE 16
		COLOR FADE PROGRAMS
	0 - 15	COLOR FADE 1
	16 - 31	COLOR FADE 2
	32 - 47	COLOR FADE 3
	48 - 63	COLOR FADE 4
	64 - 79	COLOR FADE 5
	80 - 95	COLOR FADE 6
	96 - 111	COLOR FADE 7
	112 - 127	COLOR FADE 8
	128 - 143	COLOR FADE 9
	144 - 159	COLOR FADE 10
	160 - 175	COLOR FADE 11
	176 - 191	COLOR FADE 12
	192 - 207	COLOR FADE 13
	208 - 223	COLOR FADE 14
	224 - 239	COLOR FADE 15
	240 - 255	COLOR FADE 16

COB Cannon Wash		9 Channel Mode
Channel	Value	Function
8		COLOR MACROS/PROGRAMS/ SOUND ACTIVITY
		SOUND ACTIVE PROGRAMS
	0 - 15	SOUND ACTIVE MODE 1
	16 - 31	SOUND ACTIVE MODE 2
	32 - 47	SOUND ACTIVE MODE 3
	48 - 63	SOUND ACTIVE MODE 4
	64 - 79	SOUND ACTIVE MODE 5
	80 - 95	SOUND ACTIVE MODE 6
	96 - 111	SOUND ACTIVE MODE 7
	112 - 127	SOUND ACTIVE MODE 8
	128 - 143	SOUND ACTIVE MODE 9
	144 - 159	SOUND ACTIVE MODE 10
	160 - 175	SOUND ACTIVE MODE 11
	176 - 191	SOUND ACTIVE MODE 12
	192 - 207	SOUND ACTIVE MODE 13
	208 - 223	SOUND ACTIVE MODE 14
	224 - 239	SOUND ACTIVE MODE 15
	240 - 255	SOUND ACTIVE MODE 16
9		PROGRAM SPEED/SOUND SENSITIVE
	0 - 255	SLOW - FAST
	0 - 255	LEAST SENSITIVE - MOST SENSITIVE

When Channel 7 is between the values of 0-51, Channels 1-4 are used, and Channel 5 will control strobing.

When Channel 7 is between the values of 52-102, Channel 8 is in Color Macros Mode, and Channel 5 will control strobing.

When Channel 7 is between the values of 103-153, Channel 8 is in Color Change Mode, and Channel 9 will control the color change speed.

When Channel 7 is between the values of 154-204, Channel 8 is in Color Fade Mode, and Channel 9 will control the color fade speed.

When Channel 7 is between the values of 205-255, Channel 8 is in Sound Active Mode, and Channel 9 will control the sound sensitivity.

COB Cannon Wash		10 Channel Mode
CHANNEL	VALUE	Function
1	0 - 255	RED 0% - 100%
2	0 - 255	GREEN 0% - 100%
3	0 - 255	BLUE 0% - 100%
4	0 - 255	AMBER 0% - 100%
5	0 - 31 32 - 63 64 - 95 96 - 127 128 - 159 160 - 191 192 - 223 224 - 255	SHUTTER/STROBE LED OFF LED ON STROBING SLOW - FAST LED ON STROBE PULSE SLOW - FAST LED ON RANDOM STROBE SLOW - FAST LED ON
6	0 - 255	MASTER DIMMER 0% - 100%
7	0 - 51 52 - 102 103 - 153 154 - 204 205 - 255	PROGRAM SELECTION MODE DIMMING MODE COLOR MACRO MODE COLOR CHANGE MODE COLOR FADE MODE SOUND ACTIVE MODE
8	0 - 255 0 - 15 16 - 31 32 - 47	COLOR MACROS/PROGRAMS/ SOUND ACTIVITY COLOR MACRO MODE (See page 23 for the Color Macro Chart) COLOR CHANGE PROGRAMS COLOR CHANGE 1 COLOR CHANGE 2 COLOR CHANGE 3

COB Cannon Wash		10 Channel Mode
CHANNEL	VALUE	Function
8	48 - 63 64 - 79 80 - 95 96 - 111 112 - 127 128 - 143 144 - 159 160 - 175 176 - 191 192 - 207 208 - 223 224 - 239 240 - 255	COLOR MACROS/PROGRAMS/ SOUND ACTIVITY COLOR CHANGE PROGRAMS COLOR CHANGE 4 COLOR CHANGE 5 COLOR CHANGE 6 COLOR CHANGE 7 COLOR CHANGE 8 COLOR CHANGE 9 COLOR CHANGE 10 COLOR CHANGE 11 COLOR CHANGE 12 COLOR CHANGE 13 COLOR CHANGE 14 COLOR CHANGE 15 COLOR CHANGE 16
	0 - 15 16 - 31 32 - 47 48 - 63 64 - 79 80 - 95 96 - 111 112 - 127 128 - 143 144 - 159 160 - 175 176 - 191 192 - 207 208 - 223 224 - 239 240 - 255	COLOR FADE PROGRAMS COLOR FADE 1 COLOR FADE 2 COLOR FADE 3 COLOR FADE 4 COLOR FADE 5 COLOR FADE 6 COLOR FADE 7 COLOR FADE 8 COLOR FADE 9 COLOR FADE 10 COLOR FADE 11 COLOR FADE 12 COLOR FADE 13 COLOR FADE 14 COLOR FADE 15 COLOR FADE 16

COB Cannon Wash		10 Channel Mode
CHANNEL	VALUE	Function
8		COLOR MACROS/PROGRAMS/ SOUND ACTIVITY
		SOUND ACTIVE PROGRAMS
	0 - 15	SOUND ACTIVE MODE 1
	16 - 31	SOUND ACTIVE MODE 2
	32 - 47	SOUND ACTIVE MODE 3
	48 - 63	SOUND ACTIVE MODE 4
	64 - 79	SOUND ACTIVE MODE 5
	80 - 95	SOUND ACTIVE MODE 6
	96 - 111	SOUND ACTIVE MODE 7
	112 - 127	SOUND ACTIVE MODE 8
	128 - 143	SOUND ACTIVE MODE 9
	144 - 159	SOUND ACTIVE MODE 10
	160 - 175	SOUND ACTIVE MODE 11
	176 - 191	SOUND ACTIVE MODE 12
	192 - 207	SOUND ACTIVE MODE 13
	208 - 223	SOUND ACTIVE MODE 14
224 - 239	SOUND ACTIVE MODE 15	
240 - 255	SOUND ACTIVE MODE 16	
9	0 - 255	PROGRAM SPEED/SOUND SENSITIVE SLOW - FAST
	0 - 255	LEAST SENSITIVE - MOST SENSITIVE
10	0 - 20	DIMMER CURVES STANDARD
	21 - 40	STAGE
	41 - 60	TV
	61 - 80	ARCHITECTURAL
	81 - 100	THEATRE
	101 - 255	DEFAULT TO UNIT SETTING

COB Cannon Wash		Color Macro Chart			
Color No.	DMX VAULE	RGBA COLOR INTENSITY			
		RED	GREEN	BLUE	AMBER
OFF	0	0	0	0	0
Color1	1-4	80	255	234	80
Color2	5-8	80	255	164	80
Color3	9-12	77	255	112	77
Color4	13-16	117	255	83	83
Color5	17-20	160	255	77	77
Color6	21-24	223	255	83	83
Color7	25-28	255	243	77	77
Color8	29-32	255	200	74	74
Color9	33-36	255	166	77	77
Color10	37-40	255	125	74	74
Color11	41-44	255	97	77	77
Color12	45-48	255	71	77	77
Color13	49-52	255	83	134	83
Color14	53-56	255	93	182	93
Color15	57-60	255	96	236	96
Color16	61-64	238	93	255	93
Color17	65-68	196	87	255	87
Color18	69-72	150	90	255	90
Color19	73-76	100	77	255	77
Color20	77-80	77	100	255	77
Color21	81-84	67	148	255	67
Color22	85-88	77	195	255	77
Color23	89-92	77	234	255	77
Color24	93-96	158	255	144	144
Color25	97-100	255	251	153	153
Color26	101-104	255	175	147	147
Color27	105-108	255	138	186	138
Color28	109-112	255	147	251	147
Color29	113-116	151	138	255	138
Color30	117-120	151	138	255	138
Color31	121-124	138	169	255	138
Color32	125-128	255	255	255	255

COB Cannon Wash

Photometric Chart

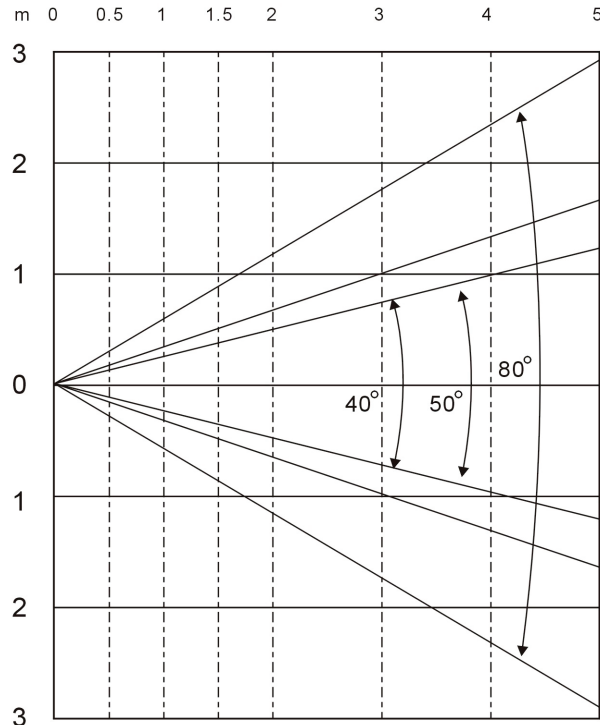

	0.5m	1m	2m	3m	4m	5m	
40°	0.4375	0.875	1.75	2.625	3.50	4.375	Diameter (Meters)
R	10650	2530	611	289	168	111	LUX
G	8490	1869	511	226	130	91	LUX
B	8540	1950	545	242	135	95	LUX
A	3110	997	253	113.8	61.1	39.1	LUX
RGBA	25900	7320	1970	810	474	297	LUX
50°	0.53	1.06	2.12	3.18	4.24	5.30	Diameter (Meters)
R	5780	1475	393	170.8	98.5	65.4	LUX
G	4760	1360	335	154.4	90.5	58.8	LUX
B	4800	1454	372	172.8	96.4	64.9	LUX
A	2480	892	191	85.4	48.8	31.4	LUX
RGBA	24300	5240	1472	681	373	240	LUX
80°	1.01	2.02	4.04	6.06	8.08	10.1	Diameter (Meters)
R	3900	975	247	112.5	66.3	44.7	LUX
G	3650	853	219	103.8	60.5	39.1	LUX
B	3660	926	246	110.4	65.9	42.5	LUX
A	2350	689	159.3	67.9	37.2	25.1	LUX
RGBA	12630	3590	996	549	238	159.9	LUX

COB Cannon Wash

Optional Lens Change

The COB Cannon Wash comes with a 80 degree lens already attached. Included in the box are optional 40 & 50 degree lenses. To switch lenses simply remove the retainer ring located in front front of the current lens. After the retainer ring has been removed carefully remove the lens, and attach your desired lens. Reinstall the retainer ring and the switch is complete. When reinstalling the retainer ring, make sure to insert 3 points of the retainer ring into the 3 notches located around the inside of the lens frame.

COB Cannon Wash

Dimmer Curve Chart

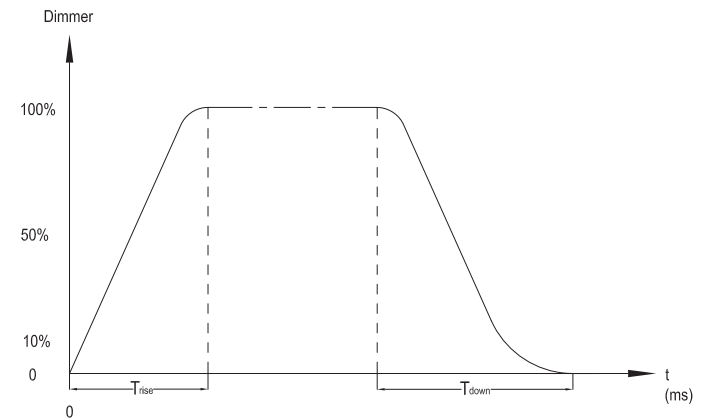

Ramp Effect	0 \rightarrow 255 0S (Fade Time)		0 \rightarrow 255 1S (Fade Time)	
	T _{rise} (ms)	T _{down} (ms)	T _{rise} (ms)	T _{down} (ms)
Standard	0	0	0	0
Stage	780	1100	1540	1660
TV	1180	1520	1860	1940
Architectural	1380	1730	2040	2120
Theatre	1580	1940	2230	2280

COB Cannon Wash

Power Cord Daisy Chain

With this feature you can connect the fixtures to one another using the PowerCON input and output sockets. The quantity that can be connected is 5 fixtures maximum. After 5 fixtures you will need to use a new power outlet. They must be the same fixtures. DO NOT mix fixtures.

COB Cannon Wash

Fuse Replacement

Disconnect the unit from its power source. Remove the power cord from the unit. Once the cord has been removed, the fuse holder is located next to the powerCON connection. Use a phillips head screwdriver to remove the fuse holder. Remove the fuse located inside the fuse holder and replace with the new fuse. Install the fuse holder and new fuse and secure it.

COB Cannon Wash

Trouble Shooting

Listed below are a few common problems the user may encounter, with solutions.

Unit not responding to DMX:

1. Check that the DMX cables are connected properly and are wired correctly (pin 3 is “hot”; on some other DMX devices pin 2 may be ‘hot’). Also, check that all cables are connected to the right connectors; it does matter which way the inputs and outputs are connected.

Unit does not respond to sound:

1. Quiet or high pitched sounds will not activate the unit.
2. Make sure that Sound Active mode is activated.

COB Cannon Wash

Cleaning

Due to fog residue, smoke, and dust cleaning the internal and external optical lenses must be carried out periodically to optimize light output.

1. Use normal glass cleaner and a soft cloth to wipe down the outside casing.
2. Clean the external optics with glass cleaner and a soft cloth every 20 days.
3. Always be sure to dry all parts completely before plugging the unit back in.

Cleaning frequency depends on the environment in which the fixture operates (i.e. smoke, fog residue, dust, dew).

COB Cannon Wash

Warranty

MANUFACTURER'S LIMITED WARRANTY

- A. ADJ Products, LLC hereby warrants, to the original purchaser, ADJ Products, LLC products to be free of manufacturing defects in material and workmanship for a prescribed period from the date of purchase (see specific warranty period on reverse). This warranty shall be valid only if the product is purchased within the United States of America, including possessions and territories. It is the owner's responsibility to establish the date and place of purchase by acceptable evidence, at the time service is sought.
- B. **For warranty service you must obtain a Return Authorization number (RA#) before sending back the product—please contact ADJ Products, LLC Service Department at 800-322-6337.** Send the product only to the ADJ Products, LLC factory. All shipping charges must be pre-paid. If the requested repairs or service (including parts replacement) are within the terms of this warranty, ADJ Products, LLC will pay return shipping charges only to a designated point within the United States. If the entire instrument is sent, it must be shipped in its original package. No accessories should be shipped with the product. If any accessories are shipped with the product, ADJ Products, LLC shall have no liability whatsoever for loss of or damage to any such accessories, nor for the safe return thereof.
- C. This warranty is void if the serial number has been altered or removed; if the product is modified in any manner which ADJ Products, LLC concludes, after inspection, affects the reliability of the product; if the product has been repaired or serviced by anyone other than the ADJ Products, LLC factory unless prior written authorization was issued to purchaser by ADJ Products, LLC; if the product is damaged because not properly maintained as set forth in the instruction manual.
- D. This is not a service contract, and this warranty does not include maintenance, cleaning or periodic check up. During the period specified above, ADJ Products, LLC will replace defective parts at its expense with new or refurbished parts, and will absorb all expenses for warranty service and repair labor by reason of defects in material or workmanship. The sole responsibility of ADJ Products, LLC under this warranty shall be limited to the repair of the product, or replacement thereof, including parts, at the sole discretion of ADJ Products, LLC. All products covered by this warranty were manufactured after August 15, 2012, and bear indentifying marks to that effect.
- E. ADJ Products, LLC reserves the right to make changes in design and/or improvements upon its products without any obligation to include these changes in any products theretofore manufactured.

No warranty, whether expressed or implied, is given or made with respect to any accessory supplied with products described above. Except to the extent prohibited by applicable law, all implied warranties made by ADJ Products, LLC in connection with this product, including warranties of merchantability or fitness, are limited in duration to the warranty period set forth above. And no warranties, whether expressed or implied, including warranties of merchantability or fitness, shall apply to this product after said period has expired. The consumer's and/or Dealer's sole remedy shall be such repair or replacement as is expressly provided above; and under no circumstances shall ADJ Products, LLC be liable for any loss or damage, direct or consequential, arising out of the use of, or inability to use, this product.

This warranty is the only written warranty applicable to ADJ Products, LLC Products and supersedes all prior warranties and written descriptions of warranty terms and conditions heretofore published.

MANUFACTURER'S LIMITED WARRANTY PERIODS:

- **Lighting Products = 1-year (365 days) Limited Warranty** (Such as: Special Effect Lighting, Intelligent Lighting, UV lighting, Strobes, Fog Machines, Bubble Machines, Mirror Balls, Par Cans, Trussing, Lighting Stands etc. excluding LED and lamps)
 - **Laser Products = 1 Year (365 Days) Limited Warranty** (excluding laser diodes which have a 6 month limited warranty)
 - **L.E.D. Products = 2-year (730 days) Limited Warranty** (excluding motors, PCB boards, and power supplies, which have a 1-year (365 day Limited Warranty) batteries which have a 180 day limited warranty). Only the L.E.D.s carry a 2-year warranty (**excluding StarTec Series which carries a 90 Day Limited Warranty**)
 - **ADJ DMX Controllers = 2 Year (730 Days) Limited Warranty** (excluding faders and tact switches)
- ADJ Products, LLC - www.adj.com - COB Cannon Wash User Manual Page 27

Model: COB Cannon Wash

Voltage:	100V ~ 240V/50~60Hz
LEDs:	1 x 150W RGBA 4-in-1 COB LED
Beam Angle:	80 Degrees (Optional 40° & 50° Lenses Included)
Working Position:	Any safe working position
Power Draw:	132W
Power Cord Daisy Chain:	5 Fixtures Max.
Fuse:	3 Amp
Weight:	9 lbs./ 4.1Kgs.
Dimensions:	16.25" (L) x 9.75" (W) x 7.5" (H) 415 x 245 x 192mm
Colors:	RGBA Mixing
DMX Channels:	7 DMX Modes: 3 Channel Mode, 4 Channel Mode, 5 Channel Mode, 6 Channel Mode, 7 Channel Mode, 9 Channel Mode, & 10 Channel Mode
Warranty:	2 Year (730 days)

Auto Sensing Voltage: This fixture contains a automatic voltage switch, which will auto sense the voltage when it is plugged into the power source.

Please Note: Specifications and improvements in the design of this unit and this manual are subject to change without any prior written notice.

ADJ Products, LLC
6122 S. Eastern Ave. Los Angeles, CA 90040 USA
Tel: 323-582-2650 / Fax: 323-725-6100
Web: www.adj.com / E-mail: info@americandj.com

A.D.J. Supply Europe B.V.
Junostraat 2
6468 EW Kerkrade
Netherlands

Follow Us On:



facebook.com/americandj
twitter.com/americandj
youtube.com/adjlighting

service@adjgroup.eu / www.adj.eu
Tel: +31 45 546 85 00 / Fax: +31 45 546 85 99